



Z1

User Manual

Welcome to the SCUBAPRO Z1 and thank you for purchasing the Z1. You are now the owner of an extraordinary partner for your dives. This manual provides you with easy access to the Z1's key features and functions.

IMPORTANT

- Before using, please make sure your new Z1 is full charged.
- Information on checking the battery power can be found on page 13.

The Z1 does not conform to 100m diver watches stated in ISO6425 and JISB7023.

Authentication Standard

R&TTE	EN 60950-1 EN 300 328 EN 301 489-1 EN 301 489-17 EN 62479
FCC	FCC Part 15

The manually initiated dive mode is compliant with the European standard EN13319.

1. Introduction

- The Z1 is a dive computer designed to support safer no-decompression diving.
- The Z1 is powered by a rechargeable battery. Recharging is accomplished by way of an integrated solar panel that generates the necessary electrical power.
- The Z1 offers multiple functions: dive computer, wristwatch, alarm, timer, stopwatch, compass, etc. In Dive Mode, information on depth, water temperature, dive time, ascent speed and decompression are provided. In Surface Mode, the Z1 provides surface interval time and desaturation time [Desat time]. In Watch Mode, it acts as a world time watch.
- The Z1 is capable of programming up to 4 different Nitrox gases. Comprehensive accelerated decompression is possible because the oxygen [O₂] level can be set from 21% to 100% in 1% increments.
- The calculation model used for the Z1's decompression program is based on the decompression theory of Dr. A. A. Bühlmann [Bühlmann ZHL16C Algorithm].

WARNING

Before using the Z1 it is important that you understand all of its warnings and cautions as outlined in this user manual.

To avoid serious accidents, please make sure to read this user manual thoroughly to enable you to fully understand the Z1. If you have any questions, contact the dealer where you purchased your Z1.

NOTE: As you engage in your diving activities, it is recommended that you always have access to this user manual. Understanding the use and functions of the Z1 ensures safer and more enjoyable diving.

2. Features & Functions

The Z1 provides the following functions.

- **Solar power to charge the battery.**
Generates electricity from the sun and other light sources.
- **Directional compass bearing.**
You can check the direction and current position of selected target.
- **Alarm setting [in Watch Mode].**
When the set time arrives, the Z1 issues an audible alarm.
- **Can be used as a stopwatch.**
Measures elapsed time.
- **Can be used as a timer [in Watch Mode].**
Counts down a pre-set time;
announces time-out with an audible alarm.
- **Provides World Time [in Watch Mode].**
Displays the time of 48 cities from around the world.
- **Transfers data using Bluetooth SMART.**
Enables the wireless transmission of log and profile data.
- **Multi-gas capable.**
Provides gas settings and switching for up to 4 gas mixes

3. Safety Precautions

Illustrations and graphics used in this user manual, and also on the display screen of the Z1 itself, incorporate various labels, icons and terms to advise you of the correct way to operate your Z1 to prevent harm or damage to you as well as to other people. This user manual also provides advisories, defined as follows:



If you ignore this serious alert and handle the product incorrectly, there is a risk of death or serious injury.



If you ignore this warning and handle the product incorrectly, there is a risk of death or serious injury.



If you ignore this cautionary indicator and handle the product incorrectly, situations can be created that can cause injury to a person or may cause physical damage.

DANGER

Make sure that you completely understand how to use your Z1, as well as all of the warnings and cautions outlined in this user manual, before taking your Z1 into the water. It is recommended that you use your Z1 in a closed water or pool environment before using it in open water.

Before using your Z1 in a scuba diving situation, you need to first take a scuba training course and obtain a certification card issued by one of the internationally acknowledged dive training organizations. [You can use the Z1 while in training under the guidance of an instructor.]

Before using the Z1 for a Nitrox [Enriched Air Nitrox, or EANx] dive, you need to complete a Nitrox dive training course. Otherwise, do not use your Z1 for Nitrox diving. [EANx is a mixed gas containing 22%-100% O₂.]

For safety's sake, when diving with your Z1, also carry a secondary computer, diver's watch and/or depth gauge as a backup.

If a "decompression stop violation" warning and/or an "out of measurement range" warning is displayed on your Z1, cancel your dive immediately and pay close attention to any changes in your physical condition.

If your Z1 fails at any time during a dive, that dive must be terminated immediately, and dive training-prescribed surfacing procedures must be initiated [including a slow ascent and a 3- to 5-minute safety stop at 15 ft/5m].

If you notice any abnormal performance with your Z1, stop using it immediately and contact the dealer where you purchased your Z1.

WARNING

- Check to make sure the battery power level your Z1 is at “H” before diving. In the event of a low power level, resulting in a warning displayed while diving, safely exit the water as soon as possible and recharge your Z1.
NOTE: If this low power warning comes on during a dive, there is still sufficient power to safely end the dive, so there is no need to panic. Deal with the situation calmly. Ref: Low Power Alarm . . . P.15
- Respond to any warnings or cautionary messages immediately.
- The Z1 should be used for recreational diving only. Do not use your Z1 for any other type of diving.
- Never lend or share your Z1 with another diver if residual nitrogen still exists in your body after using the Z1.
- Make sure to set or check the O₂% before every dive. It is extremely dangerous when the O₂% in the tank and the Nitrox setting on the Z1 don't match.
- Do not disassemble, repair, modify, or exchange the rechargeable battery or conduct pressure chamber tests on the Z1 by yourself. This is extremely dangerous and may cause a malfunction. Please see an authorized SCUBAPRO dealer for any maintenance needs.
- The Z1 is designed for dives using compressed air (21% O₂) and Nitrox (22% to 100% O₂). The Z1 cannot be used with any other mixed gas.
- Each diver should be responsible for planning and conducting the safest dives possible in accordance with his or her diving skills and physical condition.
- Please practice safe diving. Do not exceed the displayed data on your Z1. The Z1 cannot prevent you from developing decompression illness completely.
- The Z1 does not measure, display or control the air pressure in your tank. Use a separate submersible pressure gauge to monitor your tank pressure.
- If the rechargeable battery is removed from your Z1, make sure that small children do not swallow it. Put the battery out of reach of children. If swallowed, contact a doctor at once.

CAUTION

- Since the metal parts of the Z1's casing and wristband can trap dirt and contaminants which could soil the sleeves of clothing, please keep your Z1 clean at all times. After immersion in sea water, wash thoroughly with fresh water to avoid any corrosive build-up.
- Because the main casing and wristband come in direct contact with the skin, there is risk of a skin rash caused by:
 1. Dirt, rust and sweat on the casing and/or wristband as a result of poor maintenance.
 2. Allergies to metal and resin.
 3. Physical condition, etc.
- Wearing the wristband too tight increases sweat and reduces airflow between band and skin, making it much easier to develop a rash. Therefore, for everyday use it is recommended that you wear your Z1 on your wrist slightly looser rather than tighter. In the unlikely event that a rash appears, discontinue use and consult a doctor.
- To prevent unexpected injuries and allergic rashes, remove your Z1 at bedtime. Also, when holding or touching an infant, remove your Z1 to prevent rashes caused by allergies or other medical conditions.
- Always ensure that log data are stored separately from your Z1 by keeping a written log or by transferring data to a PC. A malfunction, necessary repair or dead battery could cause stored data to disappear.
- Please be sure to remove any product protection stickers before using your Z1. If you use your Z1 without first peeling off the stickers, dirt can become trapped which may cause rust and skin irritation.
- Don't drive a car or operate a boat while wearing your Z1 with the Auto-Light function turned on. The light could be distracting and might hinder driving which could be dangerous.
- The danger of explosion exists if the Z1's battery is incorrectly installed. The battery must be replaced with the same or equivalent model. Please go to your authorized SCUBAPRO dealer for any battery replacement needs.
- Do not expose your Z1 to excessive heat such from intense sunlight, fire, etc.

TABLE OF CONTENTS

1. Introduction	3
2. Features & Functions	4
3. Safety Precautions	5
4. Things To Check Before Using the Z1	13
4-1. Check the Battery Power Level	13
4-2. Charging with Light (Solar Charge)	13
4-3. How to Charge	13
4-4. Insufficient Charge or Out of Charge	14
4-5. Charging Times	15
4-6. Low Power Alarm	15
4-7. Power Saving	16
5. Mode Reference Guide	17
5-1. Mode Functions	17
5-2. Button Operation and Switching Mode	18
6. Setting Your Z1	20
6-1. Configure Home City and Daylight Saving Time Settings	22
6-2. Select 12-Hour or 24-Hour Clock	24
6-3. Set Current Time and Date	25
6-4. Set Button Operation Sound	26
6-5. Select Backlight Duration	27
6-6. Set Power Saving	28
6-7. Set Units of Measure	29
6-8. Set the MMDD/DDMM Display	30
6-9. Main Display Setting in Dive Mode	31
6-10. Set Auto Light	32

7. Watch Mode / Surface Mode(TIME)	33
7-1. Displayed Contents of Surface Mode	34
8. Dive Mode (DIVE)	35
8-1. How to Switch the Mode to Dive Mode	35
8-2. No Decompression Mode	36
8-3. Safety Stop	37
8-4. Decompression Dive	38
8-5. Warnings in Dive.....	39
8-6. Gas O ₂ % Confirmation / Gas Switch	42
9. Log Mode (LOG).....	43
9-1. Confirm the Dive History	43
9-2. Correction Function of Dive Number in Dive History.....	44
9-3. Check the Dive Log	44
9-4. Warnings Recorded in the Log	48
9-5. Setting the Dive Profile Sampling Rate.....	48
9-6. Oxygen Uptake/ppO ₂ Profile Saving Setting	49
9-7. Check the Dive Profile.....	49
10. Plan Mode(PLAN).....	52
10-1. O ₂ % Setting.....	52
10-2. Enriched Air Nitrox(EANx) Diving	53
10-3. Default Function of O ₂ %.....	53
10-4. Set Safety Factor	54
10-5. Depth Interval Alarm setting.....	55
10-6. Maximum Water Depth Warning Settings.....	56
10-7. Plan Diving	57
10-8. Display the Oxygen Toxicity Unit(OTU[UPTD])	57

11. Compass[COMP]	58
11-1. To Take a Direction Reading	58
11-2. Calibrate the Bearing	58
11-3. Digital Compass Precautions	60
12. Stopwatch[STW]	61
12-1. Stopwatch Mode	61
12-2. Measure	61
13. Timer[TMR]	62
13-1. To Enter the Countdown Timer Mode	62
13-2. Set Timer	62
13-3. Measure	63
13-4. To Stop the Alarm	63
14. Using the Alarm[ALM]	63
14-1. Select Alarm Mode	63
14-2. To Set an Alarm Time	64
14-3. To Turn an Alarm and The Hourly Time Signal On and Off	64
14-4. To Stop the Alarm	65
15. World Time[WT]	65
15-1. To Enter the World Watch Mode	65
15-2. To View the Time in Another Time Zone	65
15-3. To Specify Standard Time or Daylight Saving Time (DST) for a City	66
16. Illumination	67
16-1. To Turn on Illumination Manually	67
16-2. Automatically Light Up (Auto light)	67

17. Free Diving Mode	68
17-1. Switch to Free Diving Mode.....	68
17-2. End of Free Diving Mode.....	68
17-3. Free Diving Functions	68
17-4. Button Operation (Free Diving Mode)	69
18. Gauge Mode	70
18-1. Setting of Gauge Mode.....	70
18-2. Gauge Mode Diving.....	71
19. Bluetooth Data Transfer Mode(BLE).....	72
20. Troubleshooting	74
21. Specification	77
22. Precautions for Use	78
23. About Care	80
24. UTC (Coordinated Universal Time) and Time Zone...	83
25. City Code List	83

4. Things to Check Before Using the Z1

Before using your Z1, first you'll need to charge the unit and set the time and date. Please fully charge and match the time and date display before use.

4-1. Check the Battery Power Level

The battery's state of charge can be determined by checking whether [H], [M] or [L] is displayed at the bottom-center of the screen.

[H] or [M] displayed.	The Z1 is charged sufficiently. Set the current time. See "Configuring Current Time and Date settings."
[LOW] is blinking on the display. [L] is blinking on the display. [CHG] is blinking on the display.	Power is low. Charge the Z1 by placing it in a location where it is exposed to light.

4-2. Charging with Light (Solar Charge)

The Z1 is powered by a rechargeable battery that is charged with electricity generated by the solar panel integrated within the dial.

When sufficient light hits the dial, the battery charges. When using your Z1 on the surface, try to ensure that the dial (solar panel) is accessible to light as much as possible.

4-3. How to Charge

When not wearing your Z1, leave it in a location that is exposed to light, either outdoor sunlight or indoor fluorescent or incandescent light. Once a month, charging it in sunlight for half a day keeps your Z1 in a more stable condition. When wearing your Z1, make sure its screen is not blocked from light by the sleeve of your clothing. If the dial (containing the solar panel) is partially hidden, power generation efficiency will be reduced.



Leaving the Z1 in bright light for charging may cause it to become quite hot. Take care when handling the Z1 to avoid burn injury. The Z1 can become particularly hot when:

- Exposed for long periods of time on the dashboard of a car parked in direct sunlight.

- Kept too close to heating elements such as powerful underwater lights or incandescent lamps.
- Kept in any direct sunlight for long periods of time.

Allowing the Z1 to become too hot can cause its liquid crystal display (LCD) to black out. The LCD should normalize once the Z1 returns to a lower temperature.

4-4. Insufficient Charge or out of Charge

You can get an idea of your Z1's power level by observing the battery power indicator [H], [M], [L] at the bottom-center of the screen.

When the level of charge decreases, available functions become limited. Consequently, always make sure your Z1 maintains a full charge by making sure the dial is exposed to light as often as possible.

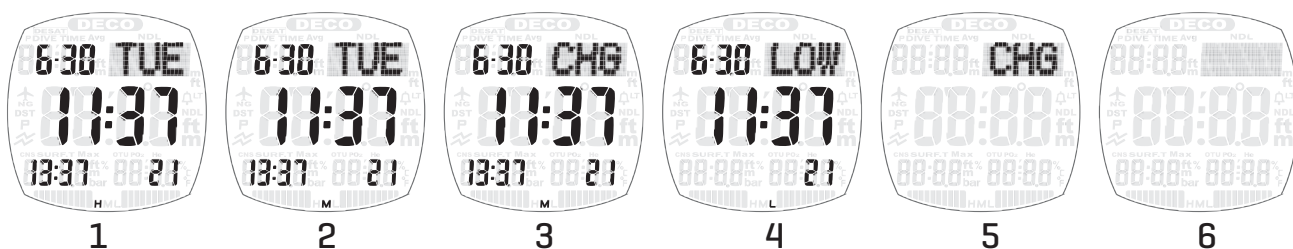

indication	Charge state	State of the Z1
H	Good	All functions enabled. [1]
M	Nearly good [Charging recommended]	All functions enabled. [2]
M CHG blinks	low battery warning	[CHG] blinks, rest of display shows OK, the Z1 can be changed to Dive Mode for about 5 hours. After that it cannot be changed to Dive mode unless charge the Z1 to a point where the [CHG] is disappear. Blue tooth connection cannot be used. Other functions can be used as usual.[3]
LOW or L blinks	low battery	[LOW] and/or [L] blinks, digital compass, illumination and beeper [alarm etc.] disabled. The Z1 cannot be changed to Dive Mode. [4]
CHG blinks [Other display disabled]	low battery	Only [CHG] blinks and other display disappears, all functions disabled. [H][M][L] and [CHG] blinks together, a part of functions enabled. [Current time display etc.] [5]
---	out of charge	All functions disabled. [6]

IMPORTANT

When the Z1's battery is depleted, all functions are disabled and settings return to their initial factory defaults. In order to reset settings such as time and date, you need to charge the Z1 to a point where the charge status at the bottom of the screen reads [M] or [H].

NOTE: Leaving your Z1 exposed to direct sunlight or some other very strong light source can cause the battery power indicator to show a reading that is temporarily higher than the actual battery level. The correct battery level should appear after a few minutes of cooling off.

4-5. Charging Times

Please use the following table as a guideline for charging.

Recharging time

Condition [luminance]	Recharging hours needed for a dive from the time low power alarm is released.	Recharging hours needed to reach full charge from the time of low power alarm.
Outdoor sunlight [50,000 lux]	1 hr.	8 hrs.
Sunlight through a window [10,000 lux]	2 hrs.	30 hrs.
Daylight through a window on a cloudy day [5,000 lux]	4 hrs.	60 hrs.
Indoor fluorescent lighting [500 lux]	36 hrs.

NOTE: Actual exposure times depend on lighting conditions.

4-6. Low Power Alarm

When battery power reaches a level too low for diving, a low power alarm sounds that includes a message urging you to recharge the battery. Since the Z1's sensors will not function when the power level decreases to the [L] level, at this point diving is not allowed.

For example, if you started a dive with the power level at [M], and during the course of the dive it dropped to [L], information relating to the dive will no longer be displayed. To avoid this dangerous situation, you should never start a dive with your Z1 unless the battery level is [H] or [M].

Current mode	Displayed alarms
Watch Mode or Surface Mode	[CHG] will blink
Dive Mode	[WARNING!!BATT] will scroll from right to left 5 times, and [M] on the lower side of the display will blink. Alarm will be on for 6 seconds. [WARNING!! BATT] will be re-shown every minute.

4-7. Power Saving

The Power Saving function, when activated, allows the Z1 to automatically enter a sleep state when it is left in a dark area for a period of time between 10:00PM and 6:00AM. The following table shows how the Z1 functions are affected by Power Saving.

Power Saving Levels	Elapsed Time	Operational Status
[Sleep State] Level 1	After 1 hour in the dark between 10 PM & 6 AM	<ul style="list-style-type: none"> · Display: Off · Sensors: Disabled · Clock & Alarms: Enabled (in background) · Ongoing Desat Calculations: · Continue Unimpeded
[Sleep State] Level 2	After 6-7 days at Level 1	<ul style="list-style-type: none"> · Display: Off · All Functions: Disabled · Alarms: Disabled · Clock: Enabled (in background)

To recover from the sleep state:

- Press any button.
- Move the Z1 to a well-lit area.
- Tilt the Z1 at an angle, as if for reading.

NOTE: When wearing the Z1, if the solar panel display is hidden beneath a shirt or jacket sleeve it may enter the Power Saving state.

More on Power Saving:

- The Z1 will not enter a sleep state while it is in Dive Mode, Stopwatch Mode or Countdown Timer Mode.
- The Power Saving function can be set to ON or OFF.
Ref: Power Saving function . . . P.28
- Sensor operation will continue for 48 hours after diving, even at Power Saving level 1.

5. Mode Reference Guide

The following chart shows the Z1's modes.

5-1. Mode Functions

Modes	Functions	Ref. page
Watch Mode and Surface Mode [TIME]	<ul style="list-style-type: none"> · To display current time, date, day · To configure Home City and daylight saving time [DST] settings 	P.33
Surface Mode [TIME]	<ul style="list-style-type: none"> · To display desaturation time [DESAT time] · To display surface time 	P.34
Dive Mode [DIVE]	<ul style="list-style-type: none"> · To display no decompression limit [NDL] · To display safety stop · To display decompression dive · To display NDL warning · Nitrox [EANx] dive 	P.35
Free Diving Mode [FREE]	<ul style="list-style-type: none"> · To display dive time · To display history · To display session information 	P.68
Log Mode [LOG]	<ul style="list-style-type: none"> · To display dive/free history · To display dive/free log · To display dive/free profile 	P.43
Plan Mode [PLAN]	<ul style="list-style-type: none"> · To display dive plan · To set safety factor [SF] · To set O₂% 	P.52
Digital Compass [COMP]	<ul style="list-style-type: none"> · To determine your current bearing or the direction from your current location 	P.58
Stopwatch [STW]	<ul style="list-style-type: none"> · To use the stopwatch to measure elapsed time 	P.61
Countdown Timer [TMR]	<ul style="list-style-type: none"> · To use the countdown timer 	P.62
Alarm [ALM]	<ul style="list-style-type: none"> · To set an alarm time · To set an alarm ON/OFF · To set an hourly time signal ON/OFF 	P.63
World Time [WT]	<ul style="list-style-type: none"> · To view the current time in one of 48 cities [31 time zones] around the globe 	P.65
Display of solar charge [SLR]	<ul style="list-style-type: none"> · Display of current charging status · Display of charging estimated time 	P.65
Bluetooth data transfer Mode [BLE]	<ul style="list-style-type: none"> · Data / setting communication · To display communication status · To set communication 	P.72

5-2. Button Operation and Switching Mode

The Z1 is operated with 4 buttons [ADJUST · MODE · LED/LOG · PLAN]. Learning the role of each button ensures easy operation.

NOTE: Button operation on the Z1 is divided into 2 methods: “press” and “press-and- hold” [for about 2 seconds]. Each method allows you to access or perform different computer functions.

MODE button

The MODE button allows you to access the Z1’s various modes. Every time you press the MODE button, it cycles through the mode menu as follows: Watch Mode [TIME] > Bluetooth Data Transfer [BLE] > Digital Compass [COMP] > Stopwatch [STW] > Timer [TMR] > Alarm [ALM] > World Time [WT] > Display Mode of Solar Charging Status [SLR].

NOTE: In any mode [other than Watch Mode], a press-and-hold [for about 2 seconds] of the MODE button will return you to Watch Mode.

ADJUST button

After entering one of the above-mentioned modes, you would use the ADJUST button to select and save the settings for that particular mode.

NOTES:

- *When the button operation sound is set to ON, your Z1 will emit a beep each time you press the MODE button. When returning to Watch Mode, a slightly higher-tone beep sounds.
Ref: Set button operation sound . . . P.26*
- *At low charge no sound will be heard. When the button operation sound is set but no sound is heard, that’s another indicator that your Z1 needs to be charged.
Ref: How to charge . . . P.13*

LIGHT/LOG button

Press the LED/LOG button to activate the backlight. Press-and-hold this button while in Watch Mode to switch to Log Mode.

Ref: To display the Dive Log . . . P.44

Ref: Automatic Light-Up [Auto Light] . . . P.67

NOTE: When set to Auto Light, the backlight turns on frequently and the capacity of the rechargeable battery decreases quickly.

From Watch Mode, you can switch to Dive Mode manually by pressing and holding the LED/LOG and the PLAN button simultaneously for about 2 seconds. *Ref: . . . P.35*

From Dive Mode, by pressing and holding the LED/LOG plus PLAN buttons again you can switch to the Freedive Mode. *Ref: . . . P.68*

And by pressing and holding the LED/LOG plus PLAN buttons for about 2 seconds yet again, you return to Watch Mode.

PLAN button

Press this button from Watch Mode to switch directly to Plan Mode.

Ref: To display Plan Mode . . . P.52

6. Setting Your Z1

IMPORTANT

Before making any other settings on your Z1 you must first set your Home City.

1. In Watch Mode or Surface Mode, press-and-hold the ADJUST button for about 2 seconds. [SET] [Hold] flashes and [CITY] appears for about 1 second, followed by the city code and the city name which will scroll in the upper right-hand corner of the screen.

Select your city code and city name by pressing the LED/LIGHT or PLAN button. *Ref. Configuring your Home City . . . P.22*

2. Once your Home city is set, press the MODE button to begin the set cycle. Each time you press the MODE button, the setting items appear in the following order:

Home City > [1] Daylight Saving Time > [2] 12/24-Hour > [3] Second > [4] Hour > [5] Minute > [6] Year > [7] Month > [8] Day > [9] Button Operation Sound > [10] Backlight Duration > [11] Power Saving > [12] Unit of Measure > [13] MMDD/DDMM > [14] Main display of Dive Mode > [15] Auto Light.

NOTE: The above numbers in [] indicate the number of times the MODE button must be pressed to reach each setting from the start position.

Ref.

<i>Setting Daylight Saving Time</i>	<i>. . . P.22</i>
<i>Setting 12/24-Hour</i>	<i>. . . P.24</i>
<i>Setting Time & Date</i>	<i>. . . P.25</i>
<i>Setting button operation sound</i>	<i>. . . P.26</i>
<i>Setting backlight duration</i>	<i>. . . P.27</i>
<i>Setting Power Saving</i>	<i>. . . P.28</i>
<i>Setting Unit of Use</i>	<i>. . . P.29</i>
<i>Setting MMDD/DDMM</i>	<i>. . . P.30</i>
<i>Setting main display of Dive Mode</i>	<i>. . . P.31</i>
<i>Setting Auto Light</i>	<i>. . . P.32</i>

3. Press the LED/LOG or PLAN button to change the following settings.

Display[e.g.]	Change item	Operation
TYO	Change city code	Press PLAN or LED/LOG button
OFF	Switch between daylight savings time and standard time	Press PLAN button
12H	Toggle between 12-hour [12 H] and 24-hour [24 H]	Press PLAN button
50	Reset seconds to "00" In the case of 30 to 59 seconds, it will be advanced by 1 minute	Press PLAN button
10:58	Change of "hour" and "minute"	Press PLAN or LED/LOG button
2018	Change of "Year"	Press PLAN or LED/LOG button
6-30	Change of "month" "day"	Press PLAN or LED/LOG button
Key 	Change ON / OFF operation of sound	Press PLAN button
LIGHT	Setting backlight lighting time	Press PLAN button
POWER SAVING	Power saving ON / OFF	Press PLAN button
UNIT	Setting unit of use	Press PLAN or LED/LOG button
MMDD	MMDD / DDMM display settings	Press PLAN button
DISP	Main display setting of dive mode	Press PLAN button
LT	Auto light setting	Press PLAN button

4. Press the ADJUST button to save your selection.

6-1. Configure Home City and Daylight Saving Time Settings

To use your Z1 you need to select your Home City and Time Zone from the 48 cities [31 time zones] in the Z1's city code list. You can also set either Standard Time or Daylight Saving Time [DST] corresponding to the country or region you find yourself in.

Ref:

- UTC [Coordinated Universal Time] and Time Zone . . . P.82
- City Code List . . . P.83

IMPORTANT

Set the Time Zone and city closest to your dive location.

NOTE: Daylight Saving Time [DST] is a time system that advances one hour from normal Standard Time. Implementation periods and areas vary from country to country, and not all countries or regions use the Daylight Saving Time system.

How to Set

1. [Assuming you haven't already done so] In Watch Mode or Surface Mode, press-and-hold the ADJUST button for about 2 seconds. [SET] [Hold] flashes and [CITY] appears for about 1 second, followed by the city code and the city name which will scroll in the upper right hand corner of the screen.

NOTE: If no further action is taken within 2 to 3 minutes, the setting screen will automatically close and return to Watch Mode.



2. Use the PLAN and LED/LOG buttons to scroll forward or backward through the available city codes. Select the city closest to your location for your Home City.
3. A press of the MODE button advances you to the Daylight Saving Time [DST] setting screen.
4. Press the PLAN button to toggle the DST setting between Daylight Saving Time [ON] and Standard Time [OFF].
5. After these settings are selected, press the ADJUST button to save the settings and return to Watch Mode. Or, press the MODE button to advance to the next setting: selecting a 12-hour or a 24-hour clock.

NOTES:

- *Daylight Saving Time is ON when the DST indicator is displayed.*
- *When the Home City is set to [UTC], the summer time [DST] setting cannot be switched.*

6-2. Select 12-Hour or 24-Hour Clock

NOTE: When using a 12-hour clock, [P] (indicating afternoon) will be visible from noon to 11:59 pm. When using a 24-hour clock [P] does not appear on the screen.



How to set

1. In Watch Mode or Surface Mode, press-and-hold the ADJUST button for about 2 seconds. [SET] [Hold] flashes and [CITY] appears for about 1 second, followed by the city code and the city name which will scroll in the upper right hand corner of the screen.
2. Press the MODE button 2 times to reach the 12H/24H setting.
3. Pressing the PLAN button, select either 12H for a 12-hour display or 24H for a 24-hour display.
4. Press the ADJUST button to capture the setting and return to Watch Mode or Surface Mode. Or, press the MODE button to move to the next settings in the series, which is Time and Date.

6-3. Set Current Time and Date

NOTES:

- *Once you set the Year, Month and Day, the Day-of-Week is automatically set.*
- *When using your Z1 outside the region of the Home City setting, it's necessary to reset the Home City to the city nearest your present location.*

How to Set

1. In Watch Mode or Surface Mode, press-and-hold the ADJUST button for about 2 seconds. [SET] [Hold] flashes and [CITY] appears for about 1 second, followed by the city code and the city name which will scroll in the upper right hand corner of the screen.
2. Press the MODE button 3 times to reach the setting for Seconds, which blinks in the lower-right corner of the screen.
3. Pressing the PLAN button resets Seconds to 00 seconds. (When Seconds read from 30 to 59, a reset advances the Minute reading by 1 minute.
4. Proceeding with the Time settings, pressing the MODE button at this point advances you to Hour > Minute > Year > Month > Day. At each point, pressing either the PLAN button or the LED/LOG scrolls you forward or backward. You can also fast-forward by pressing and holding either button.
5. After making the time and date selections, pressing the ADJUST button saves the settings and returns you to Watch Mode or Surface Mode. Or, you can press the MODE button to move to the next setting in the series, which is Button Operation Sound.

6-4. Set Button Operation Sound

When the button function audible signal is set to ON, every time you press the button an audible signal will sound, indicating the button press was successful. When this function is turned OFF, button operation is silent. The factory default for this button function is ON.

How to Set

1. In Watch Mode or Surface Mode, press-and-hold the ADJUST button for about 2 seconds. [SET] [Hold] flashes and [CITY] appears for about 1 second, followed by the city code and the city name which will scroll in the upper right hand corner of the screen.
2. Press the MODE button 9 times, bringing you to the screen where [key 🎵] or [MUTE] is displayed.

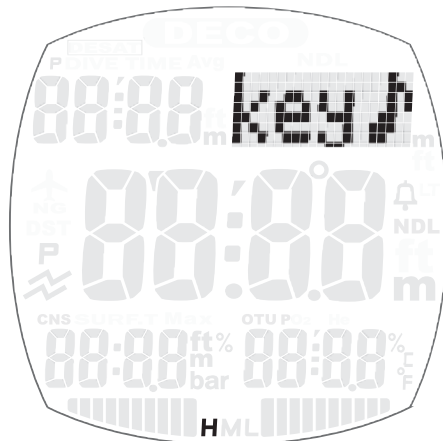

3. Press the PLAN button to select [key 🎵] [for sound] or [MUTE] [no sound].
NOTE: This setting affects only sounds resulting from pressing the control buttons. Alarm sounds, time signals, timer sounds, and warning sounds will all still be active, even if the button operation sound function is turned to MUTE.
4. Press the ADJUST button to save the setting and return to Watch Mode or Surface Mode. Or, you can press the MODE button to move to the next setting in the series, which is Backlight Duration.

6-5. Select Backlight Duration

How to Set

1. In Watch Mode or Surface Mode, press-and-hold the ADJUST button for about 2 seconds. [SET] [Hold] flashes and [CITY] appears for about 1 second, followed by the city code and the city name which will scroll in the upper right hand corner of the screen.



2. Press the MODE button 10 times. [LIGHT] is displayed, and [1] or [3] flashes in the middle of the screen.
3. Press the PLAN button to select [1] [lights the display for 1.5 seconds] or [3] [lights the display for 3 seconds].
4. Press the ADJUST button to save the selection and return to Watch Mode or Surface Mode. Or, you can press the MODE button to move to the next setting in the series, which is Power Saving.

6-6. Set Power Saving

How to set

1. In Watch Mode or Surface Mode, press-and-hold the ADJUST button for about 2 seconds. [SET] [Hold] flashes and [CITY] appears for about 1 second, followed by the city code and the city name which will scroll in the upper right hand corner of the screen.

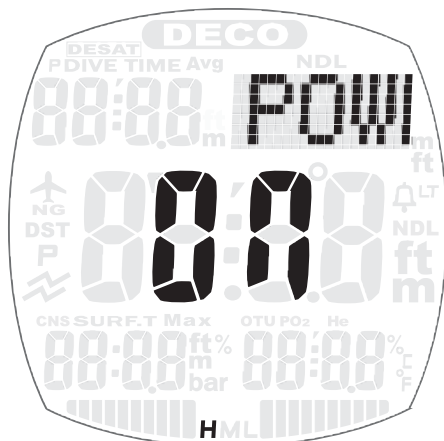

2. Press the MODE button 11 times. [POWER SAVING] appears on the screen in a scroll and [ON] or [OFF] flashes in the middle of the screen.
3. Press the PLAN button to select ON or OFF.
4. Press the ADJUST button to save the selection and return to Watch Mode or Surface Mode. Or, you can press the MODE button to move to the next setting in the series, which is Units of Measure.

6-7. Set Units of Measure

NOTE: This setting can be programmed only when using a Home City other than TYO [TOKYO].

How to Set

1. In Watch Mode or Surface Mode, press-and-hold the ADJUST button for about 2 seconds. [SET][Hold] flashes and [CITY] appears for about 1 second, followed by the city code and the city name which will scroll in the upper right hand corner of the screen.
2. Press the MODE button 12 times, [ft] or [m], and a smaller [°F] or [°C], start to blink.
3. Press the PLAN button to select [ft] or [m].

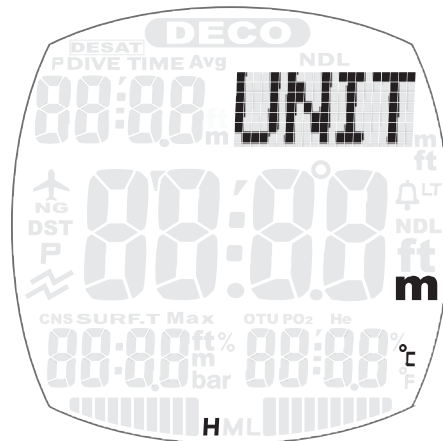

4. Press the LED/LOG button to select [°F] or [°C].
5. Press the ADJUST button to save the selections and return to Watch Mode or Surface Mode. Or, you can press the MODE button to move to the next setting in the series, which is choosing the MMDD/DDMM display.

6-8. Set the MMDD/DDMM Display

With the Z1 you can choose either the month-day or day-month display. However, this can be set only when using a Home City other than TYO (TOKYO).

How to Set

1. In Watch Mode or Surface Mode, press-and-hold the ADJUST button for about 2 seconds. [SET] [Hold] flashes and [CITY] appears for about 1 second, followed by the city code and the city name which will scroll in the upper right hand corner of the screen.
2. Press the MODE button 13 times. [MMDD] or [DDMM] will start blinking.

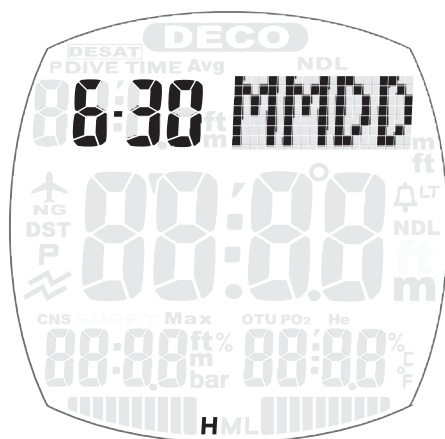

3. Press the PLAN button to select either [MMDD] or [DDMM].
4. Press the ADJUST button to save the selection and return to Watch Mode or Surface Mode. Or, you can press the MODE button to move to the next setting in the series, which is the Main Display Setting in Dive Mode.

6-9. Main Display Setting in Dive Mode

It is possible to switch the main display for Dive Mode to either no-decompression diving time or depth. The default setting is depth, indicated by DEP 1.

How to Set

1. In Watch Mode or Surface Mode, press-and-hold the ADJUST button for about 2 seconds. [SET] [Hold] flashes and [CITY] appears for about 1 second, followed by the city code and the city name which will scroll in the upper right hand corner of the screen.
2. Press the MODE button 14 times. (If you are using TYO [TOKYO] as your Home City setting, press the MODE button 12 times.) You will see either a blinking DEP 1 (indicating depth), or NDL 2 (indicating no-decompression diving time).

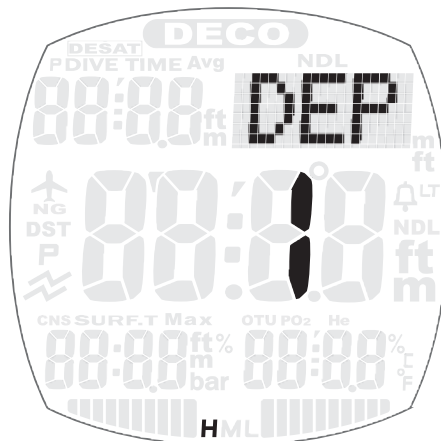

3. Press the PLAN button to select DEP 1 or NDL 2.
4. Press the ADJUST button to save the selection and return to Watch Mode or Surface Mode. Or, you can press the MODE button to move to the final setting in the series, which is Auto Light.

6-10. Set Auto Light

The Z1 offers an Auto Light function that enables the backlight to activate without manually pressing the LED/LOG button.

NOTE: The default position for the Auto Light function is OFF.

How to Set

1. In Watch Mode or Surface Mode, press-and-hold the ADJUST button for about 2 seconds. [SET] [Hold] flashes and [CITY] appears for about 1 second, followed by the city code and the city name which will scroll in the upper right hand corner of the screen.
2. Press the MODE button 15 times. [If you are using TYO [TOKYO] as your Home City setting, press the MODE button 13 times.] [LT] and ON or OFF will start blinking.

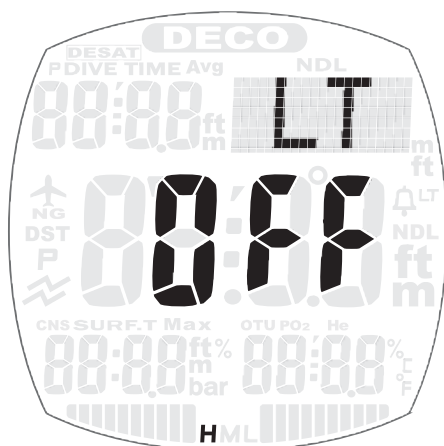

3. Press the PLAN button to select ON to activate the Auto Light setting.
4. Press the ADJUST button to save the selection and return to Watch Mode or Surface Mode.

7. Watch Mode/Surface Mode (TIME)

Watch Mode and Surface Mode display the current Time and Date.

NOTE: Surface Mode is used when nitrogen remains in the body after diving. It displays the same data as Watch Mode [current Time, Date, Day of Week], plus includes Desaturation and Surface Interval time.

Display in Watch Mode

In Watch Mode, in addition to current Time, Date, Day of Week, and World Time, when the oxygen content is set to 22% or more in the Plan Mode, the maximum value of the oxygen % is also displayed in a blinking % in the lower left corner of the screen.

[When not set to UTC, World Time is displayed in 24-hour time. When set to World Time and O₂%, oxygen content always takes priority.]



7-1. Displayed Contents in Surface Mode

The Surface Mode is a display mode used when nitrogen remains in the body after diving. In addition to normal Watch Mode data (Time, Date, etc.), the Surface Mode also displays Desaturation and Surface Time.

However, when the oxygen content is set to 22% or more in the Plan Mode, the maximum value of the O₂% is displayed alternately with Surface Time.

In Surface Mode the following information is displayed:

NO FLY icon	DO NOT board airplanes while this shows.
tissue nitrogen indicator	Amount of nitrogen accumulated in the body, displayed in 10 levels. (last line left)
oxygen uptake or ppO ₂ indicator	Amount of oxygen accumulated in the body, displayed in 10 levels. (last line right)



NOTES:

- Regardless of the presence of nitrogen and oxygen in the body, 48 hours after diving the Z1 automatically switches to Watch Mode.
- The NO FLY icon will disappear from the screen after 18 hours. Conversely, even if nitrogen saturation or oxygen uptake times out and your Z1 switches to Watch Mode, the NO FLY icon will remain until 18 hours have elapsed.
- Desaturation time varies with changes in atmospheric pressure. Therefore, desaturation time is not based on a countdown timer.

⚠ WARNING

Flying after Diving

Boarding an airplane too soon after diving greatly increases the risk of decompression sickness. Decompression sickness can also be triggered by traveling on a mountain road with an altitude considerably higher than sea level.

- NEVER fly when your Z1's NO FLY icon is displayed.
- NEVER fly when you have desaturation time still showing on your Z1.

8. Dive Mode (DIVE)

In the Dive Mode, important information for a scuba dive is shown.

8-1. How to Switch to Dive Mode

When entering the water, after a maximum of 20 seconds and a depth of 1.6m/5ft, the Z1 automatically shifts into Dive Mode. If, after entering the water, you want to enter Dive Mode sooner, press-and-hold the LED/LOG and PLAN buttons simultaneously for 2 seconds to switch to Dive Mode manually.

NOTES:

- Once you descend to 1.6m/5ft or deeper, the Z1 starts counting dive time. If you do not descend deeper than 1.6m/5ft within 1 minute of switching to Dive Mode, the Z1 reverts to Surface Mode.
- From Dive Mode, by pressing and holding the LED/LOG plus PLAN buttons simultaneously you can switch to Surface Mode or Watch Mode via the Freedive Mode.

⚠ CAUTION

If the code input display (as seen below) is shown, press the MODE button immediately to return to Dive Mode. The Z1 will revert to Dive Mode if it detects a pressure change of $\pm 20\text{cm}$ or if the code is inputted unsuccessfully. [Note: the Z1 code is 313.]

Please never enter the code during diving because it's dangerous.

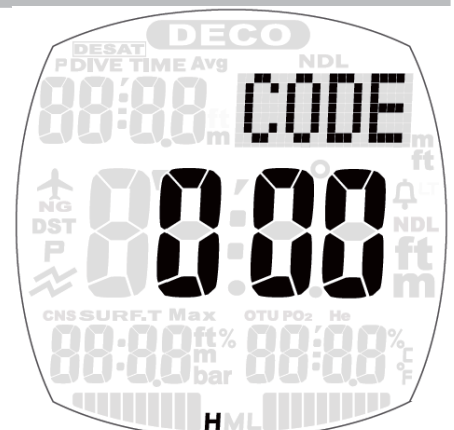

8-2. No-Decompression Mode

During no-decompression diving, the following information is displayed.

No decompression limit [NDL]	Time you can stay at the current depth without decompression. * Max. 200 minutes
Current depth	Current depth is shown, starting at a depth of 1.6m/5ft. * Max. 99.9m/328ft
Max. depth [MAX]	The maximum depth in the current dive * Max 99.9m
Current water temperature	Displays current water temperature.
Current time	Displays current time with hour and minutes *In 12H display setting, no p mark
Dive time	Time elapsed from start of dive *Max 599 minutes
O ₂ %	Display current O ₂ %
N ₂ indicator	Risk degree of nitrogen accumulated in the body is shown with 1 to 10 levels
ppO ₂ or O ₂ indicator	Risk degree of oxygen accumulated in the body is shown with 1 to 10 levels or current toxicity of oxygen accumulated in the body is shown with 1 to 10 levels * Higher level above will be shown.
Compass bearing	Refer to direction measurement. . . P.58
Stopwatch	Display elapsed time up to 0.1 second increments. Ref. . . P.61

NOTE: The O₂% display appears in Dive Mode for 10 seconds, then switches to the water temperature display. You can press-and-hold the ADJUST button to check the O₂% confirmation screen, then switch back by pressing the ADJUST button again. Maximum depth and current time will also be switched. The Dive Mode display has 3 screens, 2 of which are fixed displays with automatic switching every second.



8-3. Safety Stop

The Z1 features a Safety Stop function.

After a dive of 10m/33ft or deeper, when ascending without a decompression stop, a 3-minute countdown timer will activate at a depth of 6m/20ft. This timer will continue to run from a depth of 6m/20ft and will stay on until you reach a depth of 1.6m/5ft. It is highly recommended that you not ascend to the surface without first stopping at approximately 6m/20ft until the 3-minute timer completes its count-down.

1. At the depth of 6m/20ft, the Safety Stop alarm “pi” comes on and STOP is displayed.
2. The countdown timer displays [03:00], and the 3-minutes timer starts its countdown.
3. After 3 minutes, [↑ OK] is displayed for 5 seconds. At this point you can finish your ascent to the surface.

Operational changes at depth during a Safety Stop.

Water depth	Count-down function	display
1.5m/5ft or shallower	end [reset]	Surface Mode
1.5m/5ft~6m/20ft	normal function	Safety stop
6m/20ft~10m/33ft	stop [data is saved]	Dive Mode
10m/33ft or deeper	end [reset]	Dive Mode



NOTES:

The Safety Stop function terminates 1 of 3 ways:

1. When the 3-minute countdown timer zeros out.
2. When you ascend to less than 1.6m/5ft from the surface.
3. When you descend to 10m/33ft or deeper.

8-4. Decompression Dive

The Z1 provides the following information during a decompression dive.

Depth to stop for decompression	Displayed every 3m/10ft (3m, 6m, 9m, 12m, etc.). First (deepest) deco stop is determined by the length and depth of the dive.
DECO	Decompression dive mark. It is shown when NDL is exceeded.
Current depth	Displayed after depth of 1.6m/5ft. *Max. 99.9m/328ft
Dive time	Time elapsed from start of dive *Max 599 minutes.
N ₂ indicator	Risk degree of nitrogen accumulated in the body is shown with 1 to 10 levels.
ppO ₂ or O ₂ indicator	Risk degree of oxygen accumulated in the body is shown with 1 to 10 levels or current toxicity of oxygen uptake in the body is shown with 1 to 10 levels * Higher level above will be shown.
Total ascent time [TOTAL]	Total ascending time from current depth to the surface with the proper ascending speed including decompression stop
Decompression time	The time required for decompression at the depth
Maximum depth[MAX]	The max. depth in the current dive * Max 99.9m/328ft
Current water temperature	Displays current water temperature.
Current time	Displays current time with hour and minutes
O ₂ %	Displays current O ₂ %
Compass bearing	Refer to direction measurement. . . P.58
Stopwatch	Displays elapsed time up to 0.1 second increments. Ref. . . P.61

NOTES:

- The Z1 automatically shows Total Ascent Time and Current Time/Max Depth alternately for 3 seconds each. To manually switch from Total Ascent Time to Current Time/Max Depth, press the ADJUST button.
- For Water Temperature and O₂%, when in DECO mode, only Water Temp will be shown. To check your O₂%:



1. Press-and-hold the ADJUST button to switch to Gas Change and the current gas check display.
2. Wait until the screen returns to the DECO display.
3. Now you'll be able to switch between Water Temp and O₂% by pressing the ADJUST button.

8-5. Warnings in Dive Mode

Ascent Rate

The Z1 monitors your ascent speed and sounds an alarm when your ascent rate exceeds 10m/33ft per minute.

- When your ascent exceeds 10m/33ft per minute, a [SLO] warning appears in the center of the main display which will blink for 6 seconds. Also, an alarm will sound for 6 seconds.
- If, during an ascent, [SLO] warnings are triggered 2 times in a row, these events will be recorded in your Z1's dive log.

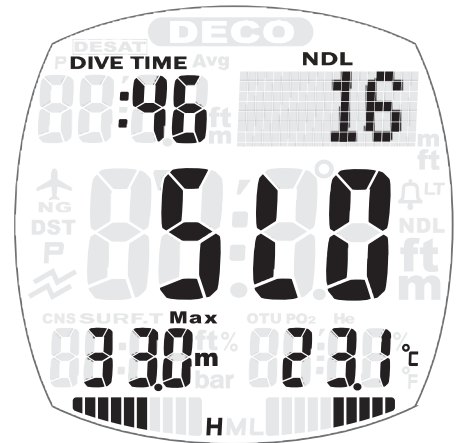

Decompression Dive

When the no-decompression limit (NDL) is exceeded during a dive, visual and audible warnings will alert you to make a decompression stop.

- DECO appears, the N₂ indicator blinks, and an alarm sounds for 6 seconds, indicating that you are now in a decompression dive.
- When you make your decompression stop at the indicated depth, DECO turns off, the N₂ indicator changes from blinking to ON, and the dive reverts to a no-decompression dive.
- The decompression dive event is then recorded in your Z1's dive log.



Decompression Stop Violation

During your ascent on a decompression dive, as you approach your decompression stop the countdown timer will start 0.5m below your decompression stop depth, and a DECO stop violation warning will start 1m above your decompression stop depth, giving you a decompression stop depth range of 1.5 meters, or about 5 feet.



For example, as you ascend on a decompression dive with a decompression stop slated for 6m, your countdown timer will start when you reach 6.5m. If, during your stop, you drift upwards as much as 1m, the deco stop violation alarm will activate.

That means for the successful completion of your decompression stop you would need to stay between 6.5m and 5m in depth.

- When your current depth is shallower than the indicated depth for a decompression stop, the [↓ DOWN] warning is shown.
- DECO will blink and an audible alarm will sound for 6 seconds.
- This warning will continue to sound until you get back to the right depth for your decompression stop, and will be recorded in your Z1's dive log.

NOTE: Always stop for decompression at the indicated depth. Do not stop at a shallower depth than indicated. If ocean conditions do not allow stopping at the indicated decompression depth, try to make your stop 1 to 2 meters deeper (3 to 6 feet) than the indicated depth, and make the stop for 1 to 2 minutes longer than the indicated time.

WARNING

By ignoring a decompression stop warning you increase your risk of developing decompression sickness. In such an event, after 3 minutes your Z1 will not be able to be used for diving for the next 48 hours. DECO and current time will continue to blink, indicating that the Z1's functions are locked.

Out of Measurement Range

A warning is given in the following conditions.

1. When depth exceeds 99.9m/328ft.
2. When dive time exceeds 599 minutes.
3. When a decompression stop is needed at 33m/108ft or deeper during a decompression dive.
4. When a decompression stop time exceeds 99 minutes or when the total ascent time exceeds 99 minutes in a decompression dive.

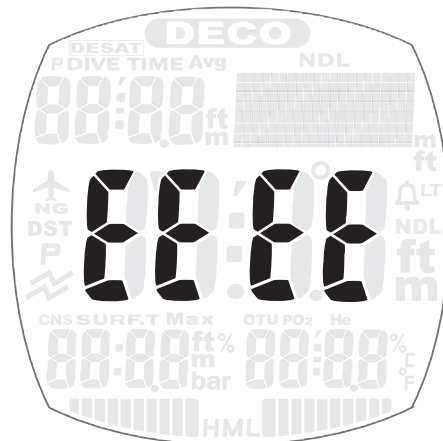

- EEEE appears in the 7-segment display area, and an alarm sounds for 3 seconds.
- The Z1 cannot be used for diving for 48 hours after the warning is activated [except when dive time exceeds 599 minutes].
- All Out of Measurement Range events are automatically recorded in the dive log.

O₂ Indicator and ppO₂

A warning is given when the oxygen accumulated in the body exceeds the tolerance level, or when the ppO₂ reaches 1.4 or more



NOTE: The higher risk event (closer to the limit) will be shown as an O₂ level warning. The screen display at right shows a ppO₂ warning. When a ppO₂ warning occurs, the ppO₂ and O₂ bar graph (lower-right) blinks, and 'PO2' blinks in the dot matrix box (upper right). When an O₂ tolerance warning occurs, the ppO₂ and O₂ bar graph blinks, and the dot matrix box remains blank.

- O₂ indicator and its ppO₂ indicator will blink.
- Alarm sounds for 6 seconds.
- The warning continues until the oxygen uptake inside the body or the ppO₂ returns to the range of tolerance. When this warning alarm sounds safely ascend to a shallower depth immediately.
- The warning is recorded in the Z1's dive log.

8-6. Setting/Switching Gas O₂%

Up to 4 gases can be programmed before a dive and switched during diving. Gas 1 is always the selected gas mixture at the beginning of a dive.



How to Set O₂%

1. Go to Plan Mode:

In Watch Mode or Surface Mode, press the PLAN button. [PLAN] appears for about 1 second, then the Z1 switches to Plan Mode. [NOTE: The Z1 will not make this switch when in Gauge Mode.]

2. Press-and-hold the ADJUST button for about 2 seconds. After [SET] [Hold] flashes, release the button when [GAS1] [21-100%] is displayed.
3. Press the LED/LOG button or the PLAN button and set the O₂% from 21% to 100%. [22% to 100% are Nitrox settings.]



CAUTION

In Nitrox [EANx] diving, the O₂% must be set for each dive. The higher the O₂% setting, the shallower the allowable maximum diving depth.

NOTE: You can press-and-hold the LED/LOG button or the PLAN button to fast-forward through the O₂% settings. The Z1 pauses at 21%, 32% and 50%.

4. For accelerated decompression using multiple gases, press the ADJUST button to open the GAS2 screen, where you can set the O₂% using the same procedure outlined above. When doing multi-gas diving, Gases 2, 3 and 4 can be set in the same way.

NOTES:

- After pressing the ADJUST button to set Gas 2, if at this point you set OFF and then press the ADJUST button again, the $O_2\%$ setting advances to the Safety Factor setting screen.
 - The $O_2\%$ setting can only be made so that the $O_2\%$ becomes Gas 1 < Gas 2 < Gas 3 < Gas 4.
5. After making your gas settings, press-and-hold the MODE button for about 2 seconds to return to Watch Mode or Surface Mode.

CAUTION

In Dive Mode it is possible to check the $O_2\%$ setting status and perform gas switching, but you cannot set or change the gas concentration setting.

How to Switch Gases

1. During a dive, press-and-hold the ADJUST button for about 2 seconds to display the gas switching/confirmation screen.
2. If multiple gases have been set, the gas number and $O_2\%$ will blink. By pressing the PLAN button, the gas number advances. If the next gas in line has not been preset, or if it cannot be dived, the Z1 will return to gas 1.

NOTE: A gas cannot be dived when the ppO_2 exceeds 1.6 bar. If a gas selected has a ppO_2 higher than 1.6 bar, a buzzer will sound and the Z1 will shift to a gas with lower $O_2\%$.

3. After confirming the gas mix, press the ADJUST button to return to the main Dive Mode screen. If 2 or 3 minutes elapse without pressing the ADJUST button, the Z1 will automatically confirm the currently selected gas and return to the Dive Mode screen.

8-7. Enriched Air Nitrox (EANx) Diving

EANx (Enriched Air Nitrox) is a mixed gas in which the percentage of oxygen exceeds that which is used in compressed air.

The Z1 can be used with compressed air (21% O₂), or with EANx (22%-100% O₂). In diving with Nitrox (EANx), in addition to tracking dive data during an air dive, the Z1 monitors the O₂ influence on the body relative to diving depth to avoid oxygen poisoning.

When Nitrox (EANx) percentages are set, the O₂% icon blinks when in Watch Mode, and O₂% and surface time are displayed alternately when in Surface Mode.

8-8. Nitrox Default Function

If the date changes while GAS1 through GAS4 oxygen percentages are set in the range of 22% to 100%, the O₂% automatically returns to the default 21% O₂ [compressed air].

8-9. Button Operation During Diving

1. Press the MODE button to switch to the Compass Mode. [Ref: . . . P.58]
2. Press the MODE button again to enter Stopwatch Mode. [Ref: . . . P.61]
3. Press the MODE button again to return to Dive Mode.
4. Every time you press the ADJUST button, the display in the lower left will alternate between Maximum Depth and Current Time.

In addition, although the lower right screen usually has a Water Temperature display, once you have confirmed the O₂% [Ref: . . . P.42], it alternates between Water Temperature and O₂%.

9. Log Mode (LOG)

You can access the Z1's Log Mode from either the Watch Mode or Surface Mode. Logs of your last 30 dives are provided, from newest to oldest. Scuba diving log data and freediving log data are mixed in chronological order. After 30 dives have been logged, as the next dive is added, the oldest log is deleted.

The Log Mode provides a look at a dive's depth variation over time using a simple dive profile. Accumulated data from the scuba diving log and from the freediving log are shown on dive history pages located at the end of the dive logs.

NOTE: In order for a dive to be recorded in the Log Mode it must last for at least 3 minutes at a depth of at least 1.6m/5ft.

9-1. Accessing Dive History

1. Go to Log Mode.
 - Press-and-hold the LED/LOG button for about 2 seconds while in Watch Mode or Surface Mode.
 - [LOG] appears on the screen and switches to Log Mode after about 1 second.

Once you switch to Log Mode you'll see the latest dive in the log displayed.

2. Press the LED/LOG button again.
 - [HIST] appears on the screen and dive history [DHIST] is displayed about 1 second later.

Total number of dives	The display of total number of dives up to now
Total dive hours	The display of total time of diving up to now
Maximum water depth	The maximum water depth dived up to now
Longest dive time	The longest dive time up to now [min]



9-2. Editing Dive Numbers in Dive History

When viewing the dive history screen [DHIST], press the ADJUST and LED/LOG buttons simultaneously and the total dive number flashes. Press the LED/LOG or PLAN to increase or decrease the number of dives. Finally, press ADJUST and the update is complete.

Press the LED/LOG button again and the freedive history [FHIST] displays.

Total number of dives	The display of total number of freedives up to now.
Total dive hours	The display of total time of freediving up to now
Maximum water depth	The maximum water depth freedived to up to now
Longest dive time	The longest freedive time up to now [min 'sec]



9-3. Checking the Dive Log

Each dive in the Log is represented by 3 screens: LOG, L-1, and L-2.

How to Check the Dive Log

1. Go to Log Mode.
 - Press-and-hold the LED/LOG button for about 2 seconds while in Watch Mode or Surface Mode.
 - [LOG] appears on the screen and switches to Log Mode after about 1 second. Once you switch to Log Mode you'll see the latest dive in the log displayed.
2. Each time you press the PLAN button a new dive is called up. Each time you press the LED/LOG button, an older dive is called up.

Press-and-hold the PLAN or LED/LOG button to fast-forward through dives.
3. When you find the dive you want to check, press the ADJUST button to toggle through LOG, L-1 and L-2 screens for that dive.
4. Press the LED/LOG or PLAN button to move to the next logged dive and repeat the process.
5. Press-and-hold the MODE button [for about 2 seconds] to return to Watch Mode or Surface Mode.

Display information on the LOG screen

Dive year/ month/date	Date you dived [year/month/day] Alternate display
DIVE/GAUGE	Diving Mode, Gauge Mode, Dive number of dives a day [See the circle in the LOG dia- gram, 2 dots in the figure = the second dive of the day]
Log No.	Log number 1 to 9999 The latest dive log is displayed with a large number
Entry time	The time you started the dive
Exit time	The time you finished the dive
N ₂ at exit time	Risk degree of nitrogen accumu- lated in the body is shown with 1 to 10 levels[*]
Oxygen uptake at exit time or ppO ₂	Risk degree of oxygen accumu- lated in the body is shown with 1 to 10 levels. Or current hazard- ous level of oxygen is shown with 1 to 10 levels[*]



LOG

Display Information on the L-1 Screen

Average water depth	The average diving depth
DIVE/WARNING/ GAUGE	Warnings released during the dive, Dive Mode, Gauge Mode
Dive Time	The time from the start to the end of the dive
Maximum water depth	The max. depth during the dive
Water tem- perature at the deepest depth	The water temperature at the deepest depth during the dive
Max. N ₂	Maximum amount of nitrogen in the body [10 levels] [*] during the dive
Max. ppO ₂	The maximum ppO ₂ [10 steps] [*] during the diving



L - 1

Display Information on the L-2 Screen

Safety factor	Safety factor settings for that dive [*]
O ₂ % /GAUGE	O ₂ % used in the tank for the dive [*]
CNS	Ratio of limit value to prevent oxygen poisoning in the central nervous system [*]
OTU	Ratio of limit value to prevent oxygen poisoning in the lungs [*]



L - 2

The following information is displayed for the Freedive Log

Display Information on the LOG Screen

Session starting year/month/date.	Date you started session [year/month/day] Alternate display
FREE	Freedive mode
Session No	Session NO. 1~9999 The latest session NO. is shown
Session starting time	The time you started freediving session
Session end time	The time you finished freediving session·the number in the session Alternate display



LOG

Display Information on the L-1 Screen

Average water depth	The average depth in the session
DEEP	Title
Dive time at maximum water depth	The time from the start to the end of the session at maximum water depth
Max. water depth	The max. depth in the dive
Water temperature at max. water depth	Water temperature at max. water depth in the dive



L - 1

[*] is not displayed in the gauge mode.

Display Information on the L-2 Screen

Total dive time	Total dive time in the session
LONG	Title
Longest dive time	The time from the start to the end in the longest dive
Water depth in the longest dive	Water depth in the longest dive
Water temperature in the longest dive	Water temperature in the longest dive



L - 2

How to Check the Freedive Log

1. Go to Log Mode.
 - Press-and-hold the LED/LOG for about 2 seconds while in Watch Mode or Surface Mode. [LOG] is displayed on the screen, and the Z1 switches to Log Mode after about 1 second.
 - When in Log Mode, the latest dive is displayed. ["FREE" means you're in the freedive log.]
2. Each time you press the PLAN button a new dive is called up. Each time you press the LED/LOG button, an older dive is called up.

Press-and-hold the PLAN or LED/LOG button to fast-forward through dives.

NOTE: The last dive log screen includes the dive history data. Just before that is the freedive history data.

Ref: Display of dive history . . . P.43

3. Go to the freedive session you want to check and press the ADJUST button. [L-1] appears on the screen followed by L-1 information about 1 second later. If you press the ADJUST button again, [L-2] appears on the screen followed by L-2 information displayed about 1 second later.
4. When you press the LED/LOG button or the PLAN button, a new or an old freedive session is called up.
5. Press-and-hold the MODE button [for about 2 seconds] to return to Watch Mode or Surface Mode.

9-4. Warnings Recorded in the Log

Following are 7 types of warnings found in a dive log.

Ascent rate	↑ SLOW	When ascent speed exceeds more than 10m/33ft per minute, warnings sound 2x.
Decompression dive	DECO is ON	When No decompression limit (NDL) is exceeded in dive and you need to stop for decompression.
Decompression stop violation	↓ DOWN	When the decompression stop depth is shallower than the indicated depth.
ppO ₂	!! PO2	When ppO ₂ becomes 1.4 or more.
O ₂	!! O2	When O ₂ in the body exceeds the tolerance.
Out of measurement range	LIMIT	<ol style="list-style-type: none"> 1. When the depth exceeds 99.9m/328ft 2. When the dive time exceeds 599 minutes 3. When decompression stop is required at depth of 33m/108ft or more at decompression diving 4. When decompression time exceeds 99 minutes at decompression diving or total ascent time exceeds 99 minutes
Maximum water depth warning	DEEP	When the warning water depth set in advance is exceeded

9-5. Setting the Dive Profile Sampling Rate

The Z1 comes from the factory with a default dive profile sampling rate with a 20-second interval. However, you can select from 10/20/30/60 seconds.

If you shorten the sampling rate interval, the amount of data logged for each dive will increase, which means the profile time will be shortened.

The Z1 can hold about 80 hours of profile data at the default sampling rate of 20 seconds. If you set the sampling rate to 10 seconds, the Z1 will be able to hold about 40 hours of data.



How to Set

- When dive log data is displayed, press-and-hold the ADJUST button for about 2 seconds to switch to the sampling rate setting screen.
- Press the LED/LOG button or the PLAN button to change the setting.
- Press the ADJUST button to save the new setting.

9-6. Oxygen Uptake/ppO₂ Profile Saving Setting

The Z1 allows you to select whether or not you want to store the oxygen uptake/ppO₂ data as part of in dive profile data. [OFF] is the default setting, which means “do not store” O₂ data.

Profile data commonly includes nitrogen uptake, warnings and O₂% data at the time of gas switching, so when O₂ uptake and ppO₂ data is being saved, N₂ and O₂ uptake and ppO₂ data will be stored alternately, and the amount of information on N₂ uptake will be cut in half. [Parts without data are complemented and displayed.]

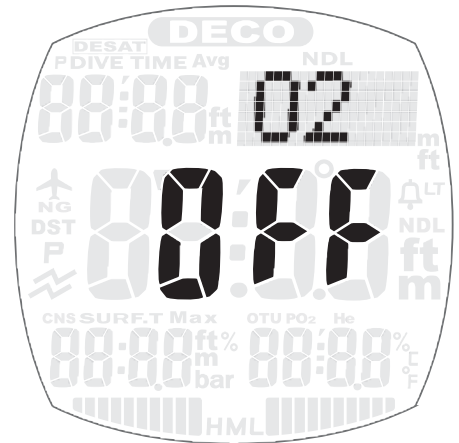

How to Set

1. When dive Log data is displayed, press-and-hold the ADJUST button for about 2 seconds to switch to the sampling rate setting screen.
2. Press the MODE button to switch to the oxygen uptake/ppO₂ profile saving display.
3. Press the PLAN button to change the setting.
4. Press the ADJUST button to save the setting.

9-7. Checking the Dive Profile

1. Go to Log Mode.
In Watch Mode or Surface Mode, press-and-hold the LED/LOG button for about 2 seconds. [LOG] appears on the screen, and the Z1 switches to Log Mode after about 1 second.

NOTE: In Log Mode, the latest logged dive is displayed.

2. Every time the LED/LOG button is pressed, it displays the newest dive in the log. Each time you press the PLAN button, the oldest dive is displayed. Press-and-hold the LED/LOG button or the PLAN button to fast-forward through all the dives.

NOTE: Between the oldest dive and the newest dive you will find the dive history.

Ref: Display of dive history . . . P.43

3. To display the logged dive you want to review, press the MODE button. [PROF] is displayed on the screen and the profile screen is displayed about 1 second later. It displays the dive profile from start to finish with a 1-second sampling rate.

When the last depth graph data is displayed, the graph is scroll-displayed. When you press anything other than the MODE button, the display stops. When you press anything other than MODE button, the automatic display stops.

Elapsed time	Display elapsed time since start of dive in minutes and seconds
Depth graph	Display water depth trajectory of 7 minutes at 20 second intervals
Depth	Display water depth at the displayed elapsed time
Warning/ O ₂ %	A warning is displayed when a warning occurs, and when the gas is switched, the switched O ₂ % is displayed
Water temperature	Display the water temperature at the displayed elapsed time
N ₂	Display the amount of nitrogen in the body at the displayed elapsed time in 10 steps
Oxygen uptake / ppO ₂	Display oxygen uptake or ppO ₂ at the displayed elapsed time in 10 steps. [default: OFF]



Warning List

Ascent rate	SLO	When ascent speed exceeds more than 10m/33ft per minute, warnings sound 2x.
Decompression stop violation	dn	When the decompression stop depth is shallower than the indicated depth.
ppO ₂	P02	When ppO ₂ becomes 1.4 or more.
O ₂	O2	When O ₂ in the body exceeds the tolerance.
Maximum water depth warning	dEP	When the warning water depth set in advance is exceeded

- Every time you press PLAN button, the sampling interval data is updated and the elapsed time advances. Every time you press LED / LOG button, the sampling interval data is updated and the elapsed time is returned. Press and hold PLAN button or LED / LOG button to fast forward.
- Pressing MODE button will display [LOG] and exit from the dive profile display.

9-8. Checking the Freedive Log Profile

The Z1's freedive log stores and displays information on your freediving sessions.

1. Go to Log Mode.

In Watch Mode or Surface Mode, press-and-hold the LED/LOG button for about 2 seconds. [LOG] appears on the screen, and the Z1 switches to Log Mode after about 1 second.

2. Every time the LED/LOG button is pressed, it displays the newest freedive session in the newest order. Each time you press the PLAN button, the oldest freedive session is displayed. Press-and-hold the LED/LOG button or the PLAN button to fast-forward through all the freedive sessions.

NOTE: The end of the freedive log [after the oldest log, and before the newest log] is the freedive history data.

Ref: Display of freedive history . . . P.43

3. To display the freedive session you want to review when the freedive profile is on the screen, press the MODE button. [PROF] is displayed on the screen and the profile screen is displayed about 1 second later. It displays the freedive profile from start to finish with a 1-second sampling rate. When you press anything other than the MODE button, the automatic display stops.

Start time	Displays start time of dive
Log No.	Displays number of dives in the session, from 1 to the total number of dives [shown as =XX=]
Dive time	Displays dive time min 'sec
Max depth	Displays maximum depth of dive
Max Temp	Displays maximum temperature at deepest depth



4. Every time you press the PLAN button, the sampling interval data is updated and the elapsed time advances. Every time you press the LED/LOG button, the sampling interval data is updated and the elapsed time is returned. Press-and-hold the PLAN button or LED/LOG button to fast-forward.
5. Pressing the MODE button will display [LOG] and exit you from the freedive profile display.

10. Plan Mode[PLAN]

With the Z1 you can plan an initial dive, a repetitive dive, or a Nitrox [EANx] dive. The Plan Mode shows your planned dive in 3m/10ft increments, starting at a depth of 9m/30ft, and going to 49m/160ft.

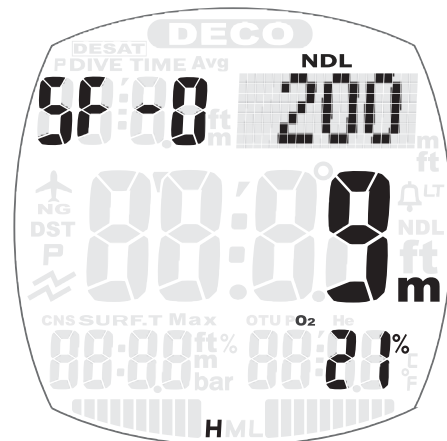

1. Go to Plan Mode.
From the Watch Mode or Surface Mode press the PLAN button which will take you to the dive planning screen.
2. Press the PLAN button to increase depth, press the LED/LOG button to decrease depth.
3. Press-and-hold the MODE button to return to Watch Mode or Surface Mode.

10-1. Set Safety Factor

The Z1 lets you adjust your decompression schedule by selecting from 3 Safety Factor levels.

depth [m ft]	9 30	12 39	15 49	18 59	21 69	24 79	27 89	30 98	33 108	36 118	39 128	42 138	45 148	48 157
SF0	200	104	66	46	35	25	20	16	14	11	9	8	7	6
SF1	200	95	60	44	33	23	19	16	13	11	9	8	7	6
SF2	180	80	52	39	30	22	17	15	13	11	8	7	6	5

*These NDLS are based on an atmospheric pressure of 1013 mbar. NDLS will change as variations occur in atmospheric pressure.

CAUTION

Once set, the Safety Factor you select will remain until you intentionally go in and change it. The Safety Factor you select will have an effect on decompression calculations during the dive, as well as your desaturation schedule after the dive.

How to Set

1. Go to Plan Mode.
Press the PLAN button in Watch Mode or Surface Mode. [PLAN] appears

in the display, and the Z1 changes to Plan Mode after about 1 second.

2. Press-and-hold the ADJUST button for about 2 seconds.
When [GAS1] [21 - 100%] appears after a blinking [SET] [Hold], release the button. [When the Gauge Mode is ON, this function is not possible.]
3. Press the ADJUST button 2 to 4 times to reach the Safety Factor setting display.
4. By pressing either the PLAN button or the LED/LOG button, you can select your Safety Factor setting: SF-0 [default] > SF-1 > SF-2.
5. Press-and-hold the MODE button for about 2 seconds to return to the Watch Mode or Surface Mode.

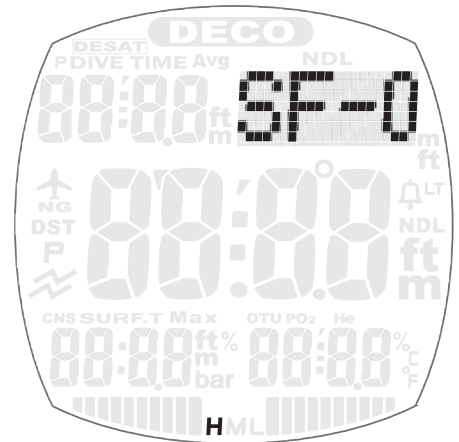

CAUTION

The Safety Factor setting cannot be checked or changed while in Dive Mode.

10-2. Depth Interval Alarm

The Z1 features a depth interval alarm function in Dive Mode, Freedive Mode and Gauge Mode that emits an audible warning of 3 beeps for each depth you set prior to the dive.

Setting the Depth Interval Alarm

1. Go to Plan Mode.
In Watch Mode or Surface Mode, press the PLAN button once, [PLAN] appears on the screen, and after about 1 second the Z1 switches to Plan Mode.
2. Press-and-hold the ADJUST button for about 2 seconds.
After [SET] [Hold] blinks, release the button when you see [GAS1] [21 - 100%].
[If the Gauge Mode is set to ON, it will switch to the interval alarm screen immediately, in which case you can move directly to Step 5.]
3. Press the ADJUST button 2 to 4 times to reach the display for Safety Factor setting.

4. Press the ADJUST button 1 more time to switch to the depth interval alarm [INT] screen.
5. Press the PLAN button to increase depths in increments of 1 meter when set to metric, or increments of 5 feet when set to imperial. You can also press the LED/LOG button to decrease depths. [When using meters: 0FF/3/4/5...98/99m. When using feet: 0FF/10/15/20... 320/325ft.
6. Press-and-hold the MODE button for about 2 seconds to return to Watch Mode or Surface Mode.



The Alarm Function

- The depth interval alarm functions in depths deeper than 3m/10ft.
- An audible alarm sounds when the depth exceeds the depth that was set. There is no screen change.
- A buffer zone of 3m/10ft is provided in order to avoid frequent warning sounds when diving near the set depth. Once you reach a depth shallower than the buffer zone of the set depth, and you return to the set depth, a warning sounds.

NOTE: If you go beyond multiple alarm points within the set depth interval time, the buzzer will only sound once.

10-3. Maximum Depth Warning

The Z1 is equipped with a maximum depth warning that sounds when the set depth is reached in Dive Mode, Freedive Mode and Gauge Mode. The default setting is OFF.

How to Set

1. Go to Plan Mode.

In Watch Mode or Surface Mode, press the PLAN button once, [PLAN] appears on the screen, and after about 1 second the Z1 switches to Plan Mode.

2. Press-and-hold the ADJUST button for about 2 seconds.
After [SET] [Hold] blinks, release the button when you see [GAS1] [21 - 100%].
[If the Gauge Mode is set to ON, at this point it will switch to the interval alarm screen immediately, in which case you can move directly to Step 5.]
3. Press the ADJUST button 2 to 4 times to reach the display for Safety Factor setting.
4. Press the ADJUST button again to switch to the depth interval alarm screen.
5. Press the ADJUST button again to switch to the maximum depth warning [DEEP] setting.
6. Press the PLAN button to increase depths in increments of 1 meter when set to metric, or increments of 5 feet when set to imperial. You can also press the LED/LOG button to decrease depths. [When using meters: OFF/3/4/5...98/99m. When using feet: OFF/10/15/20...320/325ft.
7. Press-and-hold the MODE button for about 2 seconds to return to Watch Mode or Surface Mode.

The Alarm Function

- An alarm will sound if the set depth is exceeded. It also blinks when the depth is above the set depth.
- Once it reaches the set depth, it will be entered into the log [when diving in normal Dive Mode].

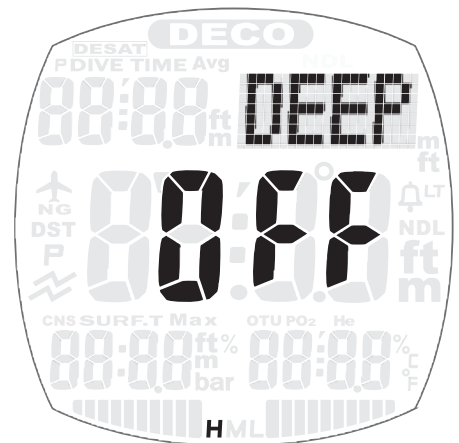

10-4. Dive Planning

1. Go to Plan Mode.

Press the PLAN button once in Watch Mode or Surface Mode. [PLAN] appears on the screen and the Z1 enters Plan Mode in about 1 second.

No Decompression Limit [NDL]	Time allowed to stay at the expected water depth *Max 200 min
Planned Depth	It can be changed every 3m/10ft from 9m/30ft to 48m/157ft

2. Press the PLAN button or the LED/LOG button to set the planned depth [9m/30ft to 48m/157ft]. The planned depth is displayed in intervals of 3m/10ft along with the no-decompression limit calculated for that depth.
3. Press-and-hold the MODE button [about 2 seconds] to return to Watch Mode or Surface Mode.

NOTE: Only gas 1 is used for dive planning. Also, when the ppO_2 exceeds 1.4 bar, 0 minutes is displayed.

10-5. Displaying the Oxygen Toxicity Unit (OTU/UPTD)

As a measure of prevention of pulmonary oxygen poisoning, display the proportion of the case where 600 is taken as 100% of the total day of OTU [UPTD] and the ratio when 2500 is taken as 100% as one week integrated.

How to Display

1. Go to Plan Mode.

Press the PLAN button once in Watch Mode or Surface Mode. [PLAN] appears on the screen and the Z1 enters Plan Mode in about 1 second.

2. When the ADJUST button is pressed, the integration for one day is displayed.

3. If you press the ADJUST button again, the accumulated amount for one week will be displayed.

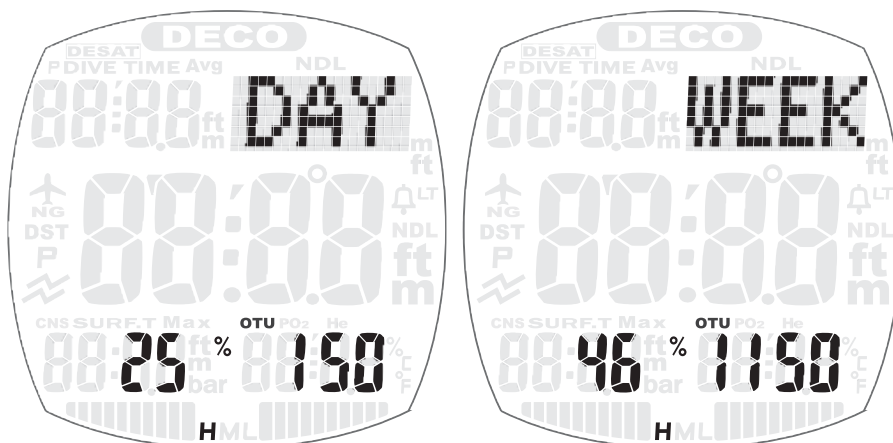

4. Press-and-hold the MODE button [about 2 seconds] to return to Watch Mode or Surface Mode.

11. Compass [COMP]

The Z1's on-board digital compass can be used in Watch Mode, Surface Mode and Dive Mode (including Gauge and Freedive). It uses a built-in sensor to take directional readings and displays the results.

NOTE: For information on how you can improve digital compass reading accuracy, see "Calibrating the Bearing Sensor" (Ref. ...P.58) and "Digital Compass Precautions" (Ref. ...P.60).

11-1. Taking a Compass Reading

1. Go to Compass Mode.
In Watch Mode or Surface Mode, press the MODE button twice and the [COMP] screen is displayed.
2. Point the 12 o' clock position of the Z1's compass in the direction of the reading you want to take.
3. Press the PLAN button while keeping the Z1 horizontal. About 1 second later, the bearing represented in abbreviated cardinal points (N, S, NW, etc.) and angle value in degrees (90°, 180°, 270°, etc.) are displayed.
4. After the first reading is obtained, the Z1 will continue to take digital compass readings automatically every second for up to 60 seconds. When reading-taking is completed, the bearing display will change to [- - -], and your Z1 will change to Watch Mode, Surface Mode or Dive Mode.



11-2. Calibrating the Compass

IMPORTANT

- During the calibration process, keep the Z1 horizontal and try to avoid wobbling or shaking the unit.
- Close proximity to strong magnetic forces (such as household appliances, mobile phones, etc.) make have an effect on calibration.
- Make sure that the 2 points to be used for calibration are in the exact opposite direction (180 degrees apart).

Calibration

1. In Compass mode, keep the Z1 horizontal and hold down the ADJUST button for at least 2 seconds. [SET] [Hold] will blink on the display. When [CALIBRATION] [- 1 -] appears, release the button. [CALIBRATION] will then scroll in the upper right hand corner of the display.

2. Press the LED/LOG button.

This begins Part 1 of the calibration process.

- [- - -] is displayed during calibration.
- When Part 1 calibration is successful, [Turn 180°] is displayed, followed by [CALIBRATION] [- 2 -] after 1 second. [If at this point [ERR] [- 1 -] appears, press the LED/LOG button and start over.]

3. Keep the Z1 horizontal and rotate it 180 degrees.

4. Press the LED/LOG button, starting Part 2 of the calibration process.

- [- - -] is displayed during calibration.
- When Part 2 calibration is successful, [OK] is displayed, and the Z1 switches to Compass Mode. This indicates that the calibration process is complete and is successful. [If [ERR] [- 1 -] is displayed, repeat the process from step 2.]

NOTE: If during this process no action is taken for 1 minute your Z1 returns to Watch Mode or Surface Mode.

IMPORTANT

Calibration cannot be performed while diving.

11-3. Digital Compass Precautions

· Magnetic North and True North

The northerly direction can be expressed either as magnetic north or true north. Magnetic north is indicated by the needle of a compass. True north, which is the location of the northern pole of the Earth's axis,



is normally indicated on maps. The difference is called declination, and it can vary depending on where on Earth you happen to be standing. For example, in the United States, declination can vary from approximately 15 degrees East on the West Coast to 15 degrees West on the East Coast.

- **Location**

Taking a compass reading when you are near a source of strong magnetism can cause errors in readings. Because of this, you should avoid taking compass readings while in the vicinity of the following types of objects: permanent magnets [magnetic necklaces, etc.], concentrations of metal [metal doors, lockers, etc.], high tension wires, aerial wires, household appliances [TVs, personal computers, washing machines, freezers, etc.].

Accurate readings are also impossible while in a train, boat, airplane, etc., and while indoors – especially inside ferro-concrete structures.

- **Storage**

The accuracy of the bearing sensor may deteriorate if your Z1 becomes magnetized. Because of this, you should store your Z1 away from magnets or other sources of strong magnetism, including: permanent magnets [magnetic necklaces, etc.] and household appliances [TVs, personal computers, washing machines, freezers, etc.].

If you suspect that your Z1 has become magnetized, try recalibrating the compass. If problems persist, take your Z1 to your authorized SCUBAPRO dealer.

- **Behavior While in Compass Mode**

- The Auto Light function will not illuminate for 60 seconds during calibration.
- If an alarm sounds during calibration or when the light is activated by pressing the LED/LOG button, calibration will be temporarily suspended and calibration will resume after the alarm is stopped or after the light is turned off.
- Atmospheric pressure and temperature will be measured up to every 20 seconds because the compass direction reading is prioritized.

12. Stopwatch (STW)

The Z1's stopwatch function can be used in Watch Mode or Surface Mode.

The Stopwatch Mode can indicate elapsed time up to 999 hours, 59 minutes and 59.9 seconds. If it exceeds the measurement range, it will return to 0 and continue its measurement.



12-1. Stopwatch Mode

In Watch Mode or Surface Mode, press the MODE button 3 times. [STW] appears on the display, and after about 1 second switches to Stopwatch Mode.

12-2. Stopwatch Operation

Button functions in Stopwatch Mode are as follows:

· To Perform an Elapsed Time Operation

PLAN Start > PLAN Stop > PLAN Restart > PLAN Stop > ADJUST Reset

· To pause at a split time

PLAN Start > ADJUST Split > ADJUST Split release > PLAN Stop > ADJUST Reset

· To measure two finishes

PLAN Start > ADJUST Split > PLAN Stop > ADJUST Split release > ADJUST Reset

First runner finishes. [Display time of first runner]

Second runner finishes [Display time of second runner]

NOTES:

- Once activated, stopwatch timing continues until you press the ADJUST button to stop it, even if you exit the Stopwatch Mode to another mode, and even if the timing reaches the stopwatch limit as defined above. To zero out the timer, press the ADJUST button again.
- Exiting the Stopwatch Mode while a split time is frozen on the display clears the split time and returns to the elapsed time measurement.

13. Timer [TMR]

The Z1's timer function can be used in Watch Mode or Surface Mode. The timer can be set from 1 minute to 24 hours. An alarm sounds for 10 seconds when time is up.



13-1. Enter the Countdown Timer Mode

Press the MODE button 4 times in Watch Mode or Surface Mode to select the Countdown Timer Mode [TMR]. About 1 second after TMR appears on the display, the display will change to show the countdown timer hours.

13-2. Setting the Timer

1. Enter the Countdown Timer Mode.
 - If a countdown is in progress, press the PLAN button to stop it, and then press the ADJUST button to reset to the current countdown start time.
 - If a countdown is paused, press the ADJUST button to reset to the current countdown start time.
2. Press-and-hold the ADJUST button for at least two seconds. After [SET] [Hold] flashes, release the button when the "hour" indicator on the timer flashes.
3. Press the MODE button to shift between the blinking hour and blinking minute settings. The one you want to select will be the one that is blinking.
4. Use the PLAN and the LED/LOG buttons to change the blinking item.
 - Press-and-hold the PLAN or LED/LOG button to fast-forward through the selection.
 - To set the starting value of the countdown time to 24 hours, set 0H 00'00.
5. Press the ADJUST button to exit the Timer set screen.
If no action is taken for 2 to 3 minutes, the Z1 automatically ends the Timer set screen.

13-3. Button Operation

The button operation of the timer measurement is as follows.



NOTE: An alarm sounds for 10 seconds when the end of the countdown is reached. This alarm will sound in all modes. The countdown time is reset to its starting value automatically when the alarm sounds.

13-4. Stopping the Alarm

Press any button.

14. Using the Alarms [ALM]

The Z1 lets you set up to 5 independent daily alarms. When turned on, an alarm will sound for about 10 seconds when it reaches its pre-set alarm time. This is true even if the Z1 is not in Watch Mode.

One of the alarms is a snooze alarm. The snooze alarm will sound every 5 minutes up to 7 times or until it is turned off. You can also turn on an Hourly Time Signal, which will cause the Z1 to beep twice every hour on the hour. The other alarms are one-time alarms.



14-1. Select Alarm Mode

Press the MODE button 5 times to select the Alarm Mode [ALM] in Watch Mode or Surface Mode. About 1 second after [ALM] appears on the display, the display will change to show an alarm name: [AL-1] through [AL-4], [SNZ] and [SIG], along with an ON/OFF indicator.

14-2. To Set an Alarm Time

1. In the Alarm Mode, press the PLAN button to scroll through the alarm screens until the one you want to set is displayed. [There is no time setting for the hourly time signal.]

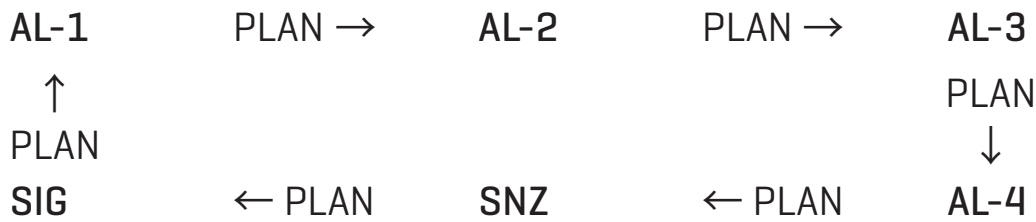

2. Press the ADJUST button until [SET] [Hold] appears on the display and the current setting starts to blink.
3. Press the MODE button to shift the blinking between the hour and minute settings.
4. Use the PLAN and LED/LOG buttons to select alarm times.
 - Press-and-hold the PLAN or LED/LOG button to fast-forward through the selection.
 - When setting the alarm time using the 12-hour format, take care to set the time correctly as a.m. [no indicator] or p.m. [P indicator].
5. Press the ADJUST button to save your setting.
6. Press-and-hold the MODE button [about 2 seconds] to return to Watch Mode or Surface Mode.

NOTE: Setting an alarm time causes that alarm to turn on automatically. If you do not take any action for 2 to 3 minutes while in the setting screen, the alarm-set process will automatically end. In such a case, the alarm that was set would be turned on.

14-3. Turning an Alarm and the Hourly Time Signal On and Off

1. In the Alarm Mode, use the PLAN button to select an alarm or the hourly time signal.
2. Once the alarm or hourly time signal is selected, press the ADJUST button to turn it ON and OFF. When 1 or more of the 4 alarms are turned on, the alarm icon lights up. [The icon will not be lit if the snooze alarm and hourly report are turned on.]

14-4. Stopping the Alarm

Press any button.

NOTES:

- Even if you switch to another mode, such as Dive Mode, an alarm sounds.
- The snooze alarm sounds up to 7 times at intervals of about 5 minutes.
- The snooze alarm will be canceled when any of the following occurs while the SNZ indicator is blinking on the display.
 - » If you turn off the snooze alarm.
 - » If you display the snooze alarm setting screen.
 - » If you display the Watch Mode or setting screen.
 - » If your Home City and World Time City are the same city, and you use the World Watch Mode to change the summer time setting of your Home City.

Ref: How to set the city and clock . . . P.25

15. World Time (WT)

You can use the World Watch Mode to view the current time in one of 31 time zones [48 cities] around the globe. The city that is currently selected in the World Watch Mode is called the "World Time City."

15-1. Enter the World Watch Mode

- Press the MODE button 6 times in Watch Mode or Surface Mode to select the World Watch Mode (WT).
- 1 second after WT appears on the display, the city code of the currently selected World Time City will scroll once in the upper right display. After that, the World Time City's city code will be displayed in the upper right display.



15-2. View the Time in Another Time Zone

In the World Watch Mode, press the PLAN button to select city codes.

- The display shows the current time of the selected city.
- Press-and-hold the PLAN button to fast-forward through the selection.

15-3. Specify Standard Time or Daylight Saving Time (DST) for a City

1. In the World Watch Mode, press the PLAN button to select city codes.
2. Press-and-hold the ADJUST button for at least 2 seconds.
 - The setting is changed when [DST] [Hold] [ON] or [DST] [Hold] [OFF] blinks.
 - » [DST] [Hold] [ON] means that Daylight Saving Time is enabled, and that the current time is advanced accordingly.
 - » [DST] [Hold] [OFF] means that Daylight Saving Time is disabled, and that the current time shows Standard Time.
 - When the display time is set to Daylight Saving Time, [DST] is displayed.

NOTES:

- *Daylight Saving Time (DST, is a system that advances the clock an hour from the normal time (Standard Time). The implementation period and the implementation area of Daylight Saving Time varies from country to country. In addition, there are countries and regions that do not use the Daylight Saving Time system.*
- *You cannot switch between Standard Time and Daylight Saving Time while "UTC" is selected as the World Time City.*
- *The Standard Time/Daylight Saving Time (DST) setting affects only the currently selected time zone. Other time zones' DST indicators are not affected.*
- *When setting a city other than UTC in World Watch Mode, the world time of the selected city is displayed in the lower left corner of the display in Watch Mode in a 24-hour display (except when setting a Nitrox mix).*

16. Display of Solar Charge (SLR)

The Z1 lets you check the status of its solar charge. You can also see the estimated time it will take to reach full charge at the current charging rate, based on the amount of available light. However, this is just an estimate and should be used as a reference only.

Display Screen Contents

- Current charging amount: the amount of light [0 to 1000] when the solar charge is set to a maximum of 1000.
- SLR: Sorter Title of Display Mode of Solar charging amount.
- Estimated Charging Time: A rough estimate of the time [0 to 999 hours] until the battery reaches a high level of charge.
- Indicator: The flash speed changes according to the current amount. The flash has no display when it has no charge.



Button Operation

By pressing the PLAN button the Z1 provides an updated re-calculation within 1 minute from the moment you press the button.

NOTE: The Z1 returns to Watch Mode if no re-measurements are done after 1 minute.

17. Illumination

The Z1's display screen is illuminated for easy reading in the dark. The light function can be set for manual operation, or you can set the Auto Light function which activates the backlight by tilting your arm in the dark, using the Z1's ambient light sensor.

17-1. Manual Activation

When the LED/LOG button is pressed in any of the primary modes, the backlight lights up. [This includes Dive Mode.]

NOTE: When an alarm sounds while the backlight is illuminated, the light will immediately turn off. Also, the backlight is disabled while configuring mode settings.

17-2. Automatic Activation (Auto Light)

When the Z1's Auto Light function is set, the backlight will turn on when the Z1 is tilted more than 40 degrees. [When setting Auto Light, the LT mark is lit.]

NOTES:

- *The Auto Light does not activate in bright places.*
- *The Auto Light does not operate when the alarm tone is ringing or when you are taking a compass bearing. [The Auto Light does operate after taking the bearing; however, there may be a delay before lighting.]*

Ref: Setting the Auto light . . . P.32

Using the Auto Light

- If the Z1 is inclined more than 15 degrees from the horizontal state, it will be difficult to light up.
- If the Z1 is hidden under a shirt sleeve, the light will be constantly lit and the charge will decrease.
- The Auto Light function may not work due to static electricity or magnetism. In such a case, return the Z1 to a horizontal position.
- When the Z1 is tilted, there may be a situation where sound emits from inside the unit. This is the operational sound of the Auto Light switch and is not a malfunction.

18. Freedive Mode

The Z1 features a Freedive Mode for use while skin diving and freediving.

Because nitrogen gas fluctuation is not calculated in the Freedive Mode, the N₂ tissue loading bar graph is not displayed. Also, displays such as no-decompression dive time as well as various warnings, such as the ascent rate warning, are not shown.

18-1. Switching to Freedive Mode

In Watch Mode or Surface Mode, press-and-hold the LED/LOG button and then press the PLAN button twice to switch to Freedive Mode.

NOTE: if desaturation time remains on your Z1 after scuba diving; or if your Z1 is in a 48-hour lock-down due to a violation; or if your Z1 is in Gauge Mode; or if the battery charge level is low, it will not be possible to access the Freedive Mode.



18-2. Ending a Freedive Session

- Press-and-hold the LED/LOG button and the PLAN button simultaneously to switch to Watch Mode or Surface Mode.
- A freedive session is also automatically terminated if no dive activity occurs for more than 60 minutes at a depth of more than 1m/3ft.
- However, if you press the PLAN button while also pressing the LED/LOG button in a situation where the dive is more than 1m/3ft in depth, the Freedive Mode will not end – although if this situation persists at more than 1m/3ft in depth for 99 minutes, your Z1 will automatically terminate the freedive session.

NOTE: Freedives of more than 1m/3ft in depth will be saved as one session in the Freedive Log.

18-3. Freedive Mode Functions

If you switch to the Freedive Mode and dive to a depth of 1m/3ft or deeper, the Z1 switches to the freedive screen and the display alternates every second between the primary freedive screen and the number of dives in the freediving session.



18-4. Button Functions in Freedive Mode

1. Pressing the MODE button takes you to Compass Mode.
2. Pressing the MODE button in Compass Mode takes you to Stopwatch Mode.
3. Pressing the MODE button in Stopwatch Mode takes you to Dive Mode.
4. Pressing the ADJUST button displays the history of the current session.



5. Pressing the ADJUST button, when displaying the history of current session, displays the maximum depth of the current session.



6. Pressing the ADJUST button, when displaying the maximum depth of the current session, displays the longest dive of the current session.

7. Pressing the ADJUST button, when displaying the longest dive of the current session, returns you to the Freedive Mode home screen.



19. Gauge Mode

In Gauge Mode, the Z1 does not calculate no-decompression dive time or decompression dive time. Gauge Mode provides only basic data like depth and dive time.

19-1. Activating Gauge Mode

1. In Watch Mode or Surface Mode, press the PLAN button to go to Plan Mode.
2. Press-and-hold the ADJUST button for about 2 seconds. After [SET] [Hold] blinks, release the button when you see [GAS1] [21-100%]
3. Press-and-hold the ADJUST button for about 2 seconds again. After [SET] [Hold] blinks, release the button when you see a blinking [GAUGE] [OFF]
4. Press PLAN to select ON.
5. Press-and-hold the MODE button for about 2 seconds. This locks in Gauge Mode and returns you to Watch Mode or Surface Mode.

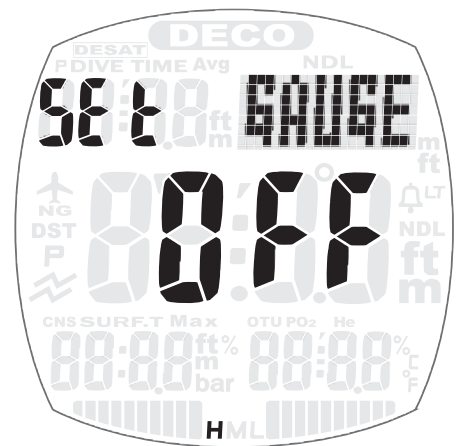

NOTE: Gauge Mode is not set to ON in the nitrogen accumulation state. When you select Gauge Mode and dive for 3 minutes or more, the unit is locked to Gauge Mode for 48 hours after the dive ends and you cannot switch to Dive Mode [computer function] or Freedive Mode. If Gauge Mode is turned ON, Safety Factor and O₂% are not displayed.

19-2. Gauge Mode Diving

Button Operation In Gauge Mode

1. Press the MODE button to enter the Compass Mode.
2. Press the MODE button again to enter Stopwatch Mode.
3. Press the MODE button again to return to the Gauge Mode home screen.



Display

Dive time	Time elapsed from diving start *Max. 599 min
GAUGE	Title
Depth	Current depth resolution is 0.1m [1ft] *Max 99.9m/328ft
Max depth [MAX]	Maximum water depth in the dive *Max 99.9m/328ft
Water temperature	Display current water temperature
Compass Bearing	Ref. Digital compass . . . P.58
Stopwatch	Display elapsed time up to 0.1 second increments . . . P.61

19-3. Turning Gauge Mode Off

1. In Watch Mode or Surface Mode, press the PLAN button to go to Plan Mode.
2. Press-and-hold the ADJUST button for about 2 seconds. After [SET] [Hold] blinks, release the button when a blinking [INT] appears.
3. Press-and-hold the ADJUST button again for about 2 seconds. Gauge [SET] [ON] blinks.
4. Press the PLAN button to select [GAUGE] [SET] [OFF]
5. Press the ADJUST button to save the new setting.
6. Press-and-hold the MODE button for about 2 seconds to return to Watch Mode or Surface Mode.

NOTE: When you select Gauge Mode and dive for 3 minutes or more, the unit is locked to Gauge Mode for 48 hours after the dive ends and you cannot switch to Dive Mode [computer function] or Freedive Mode. If Gauge Mode is turned ON, Safety Factor and O₂% are not displayed.

20. Bluetooth Data Transfer Mode (BLE)

By setting your Z1 to Bluetooth Data Transfer Mode, you can transfer dive data wirelessly to various desktop and hand-held devices, and you can also use it to make adjustments in your Z1 settings.

NOTE: You'll need to prepare a corresponding smartphone application separately. You can search "Z Dive Log" in the app store or install it from the QR code below.

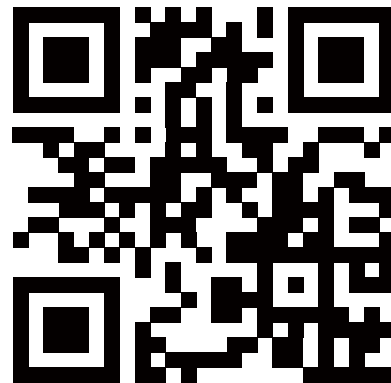

Operation

1. Press the MODE button from Watch Mode or Surface Mode to take you to the Bluetooth screen.
2. Press the PLAN button to turn the Bluetooth function ON.



When the Z1 shifts to the communication state of the smartphone application, it switches to the display shown here. If communication with the smartphone application fails, it will automatically turn off in about 30 seconds.



3. When communication is completed, press the PLAN button to turn it OFF. OFF blinks for about 5 seconds before turning completely OFF. Even if you press the PLAN button during this time it will not turn back ON. If you need to turn it on again, wait until after the flashing ends.
4. Press-and-hold the MODE button to return to Watch Mode or Surface Mode.

NOTE: When there is no data transmission/reception in the communication state with the smartphone application, the Z1 turns off automatically in about 10 minutes.

Depending on the smartphone, it may not be possible to find the Z1 from the application. In this case, you can connect by changing the interval time [4 types].

1. Press the MODE button from Watch Mode or Surface Mode to take you to the Bluetooth screen.
2. Press-and-hold the ADJUST button (about 2 seconds). [Set] [hold] will blink and display [INT], at which point you release the button.
3. Press the PLAN button or the LED/LOG button to increase or decrease the interval time.
4. Press the ADJUST button to save the new interval time setting.
5. Press-and-hold the MODE button to return to Watch Mode or Surface Mode.



21. Troubleshooting

<Diving>

Situation	Cause and Remedy
Display is too light	Display may become light in low temperatures. Please wait for a while. If situation does not change, please contact the shop where you purchased the Z1.
Dive log is already installed in a newly purchased Z1	Test data is installed for quality checking at the factory before shipping. It is not a malfunction.
DECO and current time are blinking on the surface.	Decompression stop violation warning is displayed. If you descend to the requested depth again for decompression stop within 3 minutes after the warning is shown, the warning will be cancelled. If over 3 minutes passes, the Z1 cannot be used within the next 48 hours for diving.
EEEE and current time are shown in turn	Out of measurement range warning is displayed. The Z1 cannot be used within the next 48 hours for diving.
The number of O ₂ [%] is blinking in watch mode	When O ₂ % was set between 22 to 100% in Nitrox gas [EANx gas], the number of O ₂ [%] is blinking on the display. When you dive with Nitrox gas, be sure to reset the O ₂ %. Ref. Set O ₂ % . . . P.52
Cannot enter Dive Mode	<ul style="list-style-type: none"> · Either Decompression stop violation or Out of measurement range warning is displayed. The Z1 cannot be used for 48 hours after the warning is displayed. After this time, it will return to normal mode automatically. · The altitude is detected as approx. 6,000m/19,700ft. Please wait for a while or move to a lower altitude. · Power level is low. Check the power level. Ref. Confirm charge amount . . . P.13 If none of above applies, sensor might be a problem. Please contact the shop where you purchased the Z1.
During a flight or while moving to a high altitude, the Z1 goes into Dive Mode.	This happens when there is a sudden change in atmospheric pressure. This is not a malfunction. [000] flashes when you press-and-hold the LED/LOG plus PLAN buttons for 2 seconds simultaneously. It returns to Watch Mode when you input [313] with the LED/LOG or PLAN button.

<Time setting>

Situation	Cause and Remedy
The current time setting is off by hours	Your Home City setting may be wrong. Check your Home City setting and correct if necessary. Ref. Set home city, daylight saving time . . . P.22

Display of current time is deviated by one hour	It is necessary to set the time corresponding to the current daylight saving time. Ref. Set home city, daylight saving time. . . P.22
---	--

<Sensor>

Situation	Cause and Remedy
[ERR] appears on the display while using a sensor	<p>Subjecting Z1 to strong impact can cause a sensor malfunction or damage internal circuitry. When this happens, ERR [error] will appear on the display and sensor operations will be disabled.</p> <ul style="list-style-type: none"> · If ERR appears while a reading operation is being performed in Digital Compass Mode, restart the operation. If ERR appears on the display again, it can mean there is something wrong with the sensor. · If ERR keeps appearing during a reading operation, it could mean there is a problem with the applicable sensor. Please contact the shop where you purchased the Z1.

<Digital Compass>

Situation	Cause and Remedy
ERR appears on the display after performing a compass calibration.	<p>If [---] appears and then changes to [ERR][error] on the calibration screen, it means that there is something wrong with the sensor.</p> <ul style="list-style-type: none"> · If [ERR] disappears after about 1 second, try performing the calibration again. · If [ERR] keeps appearing, contact the shop where you purchased the Z1.
What causes incorrect compass readings?	<ul style="list-style-type: none"> · Incorrect calibration. Ref. Calibration . . . P.58 · Nearby source of strong magnetism, such as a household appliance, a large steel bridge, a steel beam, overhead wires, etc., or an attempt to take direction readings on a train, boat, etc. Move away from large metal objects and try again. Note that digital compass operation cannot be performed inside a train, boat, etc. <p>Ref. Digital Compass Precautions . . P.60</p>
What causes different compass readings to produce different results at the same location?	<p>Magnetism generated by nearby high-tension wires is interfering with detection of terrestrial magnetism. Move away from the high-tension wires and try again.</p>
Why am I having problems taking compass readings indoors?	<p>A TV, personal computer, speakers, or some other object is interfering with terrestrial magnetism readings. Move away from the object causing the interference or take the compass reading outdoors. Indoor compass readings are particularly difficult inside ferro-concrete structures. Remember that you will not be able to take compass readings inside of trains, airplanes, etc.</p>

<World Watch Mode>

Situation	Cause and Remedy
The time for my World Time City is off in the World Watch Mode	This could be due to incorrect switching between standard time and daylight saving time. Ref. Setting Daylight Saving Time [DST] . . . P.66

<Charging>

Situation	Cause and Remedy
All [H][M][L] are blinking	<p>When in Power Recovery Mode, battery power will recover in about 15 minutes. Exposing the Z1 to bright light reduces recovery time.</p> <ul style="list-style-type: none"> · Performing multiple operations over a short period runs down the battery rapidly, which will cause the Z1 to change to Power 100 Recovery Mode. In this mode, all of the battery power indicators [H][M][L] will be blinking. It is the same situation as [Low power] and available functions will be limited. After recovery, the functions are enabled again. <p>Ref. Insufficient charge or out of charge . . . P.14</p> <ul style="list-style-type: none"> · If all of the battery power indicators [H][M][L] are blinking with [CHG], it means the battery level is very low. Expose the Z1 to bright light as soon as possible.
Need to repeatedly recharge the battery.	The battery is recharged by light striking the solar panel, so you don't need to replace the battery regularly. However, battery quality deteriorates after long periods of repeated charging and discharging. If you're having trouble with use, we recommend you replace the battery. Please contact the shop where you purchased the Z1.

22. Specifications

Accuracy at normal temperature	±15 seconds a month
Timekeeping, Calendar system	Hour, minutes, seconds, year, month, day, day of the week, p.m. [P], /Time format: 12-hour and 24-hour, Full Auto-calendar pre-programmed from the year 2000 to 2099
Sensor Accuracy	<ul style="list-style-type: none"> ·Direction sensor accuracy ±10 ° guaranteed in the temperature range of -10~60°C ·Temperature sensor accuracy ±2 ° guaranteed in the temperature range of -10~60°C ·Pressure sensor accuracy ±1%+0.5m guaranteed in the temperature range of -5~40°C
Measuring interval	water depth every 1 second (every 0.5 second in free diving) water temperature every 1 second (every 0.5 second in free diving) air pressure every 20 seconds
Measuring range	water depth 1.6m to 99.9m dive time 0 to 599 minutes altitude 0 to 6000m temperature -10~ 60°C (Dive related display is displayed up to 40 ° C)
O ₂ %	21% [compressed air] to 100% in every 1%
Water proof	100m
Max. dive log	30 dives
Digital Compass	Angle value 0° to 359°, Calibration [bidirectional]
Stopwatch	Measuring unit 1/10 second Measuring capacity 999:59' 59.9" Measuring accuracy ±0.0006% Measuring modes Elapsed time, split time, two finishes
Alarms	4 one-time alarms 1 snooze alarm unit hour·minute Alarm sound time 10 seconds Hourly time signal notify by electronic sound twice every hour
Other	LED light, Selectable illumination duration, Auto Light Switch, Power saving, Battery power indicator, Button operation tone on/off
Battery	rechargeable battery
Battery duration	About 1 month from full charge state [1 60-minute dive/1 dive a day]

22. Precautions for Use

Waterproofing

- In order to maintain your Z1's waterproofness, it is recommended that you periodically have the O-rings replaced during maintenance.
- A waterproof inspection will be conducted when the battery is replaced, so be sure to tell your dealer so he can determine the proper maintenance interval.
- If your Z1 is suddenly subjected to extreme cold, the inside of the glass may become cloudy. However, this shouldn't present a problem as long as the cloudiness disappears relatively soon. If the cloudiness persists, or if water is visible inside, stop using your Z1 immediately and consult your dealer.

Wristband

- Cinching your wristband too tight increases body sweat beneath the band and reduces airflow, making it easier to develop a rash. For daily use, allow a margin of space between your wrist and the Z1 wristband.
- Stop using your Z1 if the wristband loses its elasticity, if cracks appear, if discoloration occurs, or if the wristband junction pin loosens. Consult with your dealer for inspection and repair.

Temperature

- Do not leave your Z1 in high-temperature areas such as on an automobile dashboard or near heating equipment. Conversely, do not leave your Z1 in areas where there are persistent cold temperatures. Either scenario may result in a malfunction.

NOTES:

- *Too long spent subjected to excessive heat may interfere with the Z1's liquid crystal panel [60°C/140°F or higher].*
- *Too long spent subjected to any excessive temperature and the Z1's liquid crystal display may become difficult to see [0°C/32°F or less, or 104°F/40°C or more].*

Shock

- Dropping or striking your Z1 against a solid object may cause a system failure.

Magnetism

- If your Z1 becomes magnetized due to its close proximity to equipment with strong magnetism, accuracy could be affected. Such close proximity may also damage electronic components and cause a malfunction.

Static Electricity

- Your Z1 may display incorrect information due to static electricity. Extremely strong static electricity can also damage electronic parts. Static electricity may temporarily blur the part of the liquid crystal that is not illuminated.

Chemicals

- Damage to your Z1 may occur if it comes into contact with paint thinner, gasoline, a variety of solvents, fats, oils and cleaners, as well as adhesives, paints, chemicals, cosmetics, etc.

Storage

- Before storing your Z1, make sure to wipe away any dirt, sweat, moisture, etc. and avoid storing in hot and/or humid places.

Resin Parts

- If your Z1 is kept in close contact with other gear for extended periods, especially if wet, coloration from the other gear may get transferred over to your Z1. Consequently, before storing your Z1 make sure to wipe off any moisture and then keep it separated from your other gear.
- Your Z1's color may fade, or may be stained if exposed to direct sunlight (ultraviolet rays) for long periods of time.
- Painted parts may wear thin or discolor due to repeated use.

Liquid Crystal Display

- Depending on the viewing angle and presence of ambient light, the liquid crystal display may be difficult to see.

Protecting Dive Data

- During a battery replacement, or during a troubleshooting session, it is possible to lose dive logs and other data content. SCUBAPRO is not responsible for any damage or lost profit due to the loss of data caused by a breakdown, repair, battery replacement, etc. Consequently, we recommend that you back up your data by copying or saving it to a separate platform, or by keeping notes.

About the Sensor

- Since your Z1 is a precision machine, never attempt to disassemble it. Also, be careful not to pierce the sensor part of your Z1 with a thin rod as this may cause dust to enter. Always rinse with fresh water after using your Z1 in salt water.

IMPORTANT

In the unlikely event of failure, SCUBAPRO is not responsible for any damages caused by lost profits or any claims from third parties.

24. Care & Maintenance

How to Care for Your Z1

- Frequently wipe away dirt, sweat, moisture, etc., with a soft cloth.
- After use in salt water or in close proximity to mud, rinse thoroughly with fresh water after a short freshwater soak.
- For the metal components of both the metal band and resin band, scrub with a soft toothbrush and soapy water. Then rinse well with fresh water and wipe off residual moisture with a soft hygroscopic cloth.
- Wash the resin band with fresh water and wipe off residual moisture with a soft cloth. You may find a spot-like pattern on the surface of the resin band; however, there is no effect on the human body and clothing.
- If you do not operate the buttons for a long time, their movement may become stiff. From time to time, press the buttons to loosen up the button action.

Failure to Care for Your Z1

Rust

- The metal used on the Z1 is rust-resistant, but rust can be caused by dirt. [When oxygen is cut off due to dirt, the oxide film on the surface cannot be maintained and rust occurs.]
- If rust occurs, a sharp point may be formed in the metal parts, or the wristband pin may pop out. If you notice any abnormality in metal parts, return your Z1 immediately to your dealer for repair.
- Even if the surface of your Z1 appears clean, dirt and rust can collect in crevices which can potentially soil the sleeves of clothing, cause a skin rash, or deteriorate the performance of your Z1.

Deterioration

- Allowing your Z1 to remain wet from moisture such as sweat, or storing it in a humid place, can cause deterioration of the resin band and resin bezel, increasing the possibility of a breakdown.

Rash

- Depending on the condition of your Z1 and the condition of your skin, the wristband – especially a resin band – can cause a rash. Always keep your Z1 clean and dry. If you do get a rash, stop wearing your Z1 and consult a dermatologist.

About the Batteries Used in Your Z1

- The Z1 uses a rechargeable battery. Please do not remove the battery yourself. Attempting to replace it with anything other than the approved rechargeable battery will cause damage.
- The Z1's battery is recharged by way of electricity generated by sunlight or certain types of artificial light captured by the integrated solar panel; therefore, the Z1's battery only rarely has to be replaced.
- However, after long periods of time and repeated charges and discharges, the efficiency of the battery will eventually deteriorate. If you are experiencing trouble with your Z1 maintaining a charge, we recommend you contact your dealer to see if it needs a battery replacement.

Please check the time zone of the destination from the map.

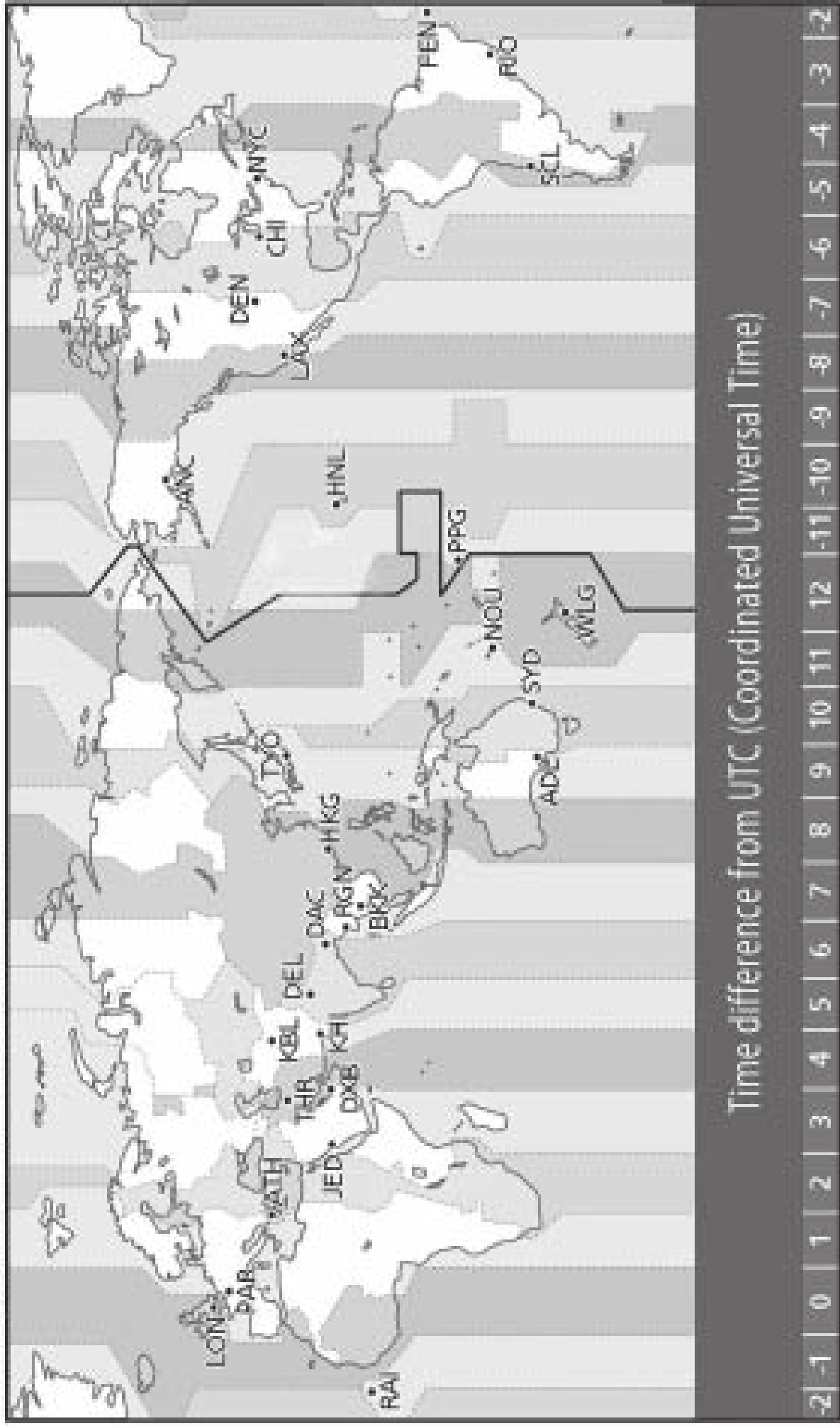

25. UTC (Coordinated Universal Time) and Time Zone

Please check your time zone from the world map on the previous page.

26. City Code List

The following table is the city code list for the Z1.

City	Code	Time Zone
UTC [Coordinated Universal Time]		0
LISBON	LIS	0
LONDON	LON	0
MADRID	MAD	+1
PARIS	PAR	+1
ROME	ROM	+1
BERLIN	BER	+1
STOCKHOLM	STO	+1
ATHENS	ATH	+2
CAIRO	CAI	+2
JERUSALEM	JRS	+2
MOSCOW	MOW	+3
JEDDAH	JED	+3
TEHRAN	THR	+3.5
DUBAI	DXB	+4
KABUL	KBL	+4.5
KARACHI	KHI	+5
DELHI	DEL	+5.5
KATHMANDU	KTM	+5.75
DAHKA	DAC	+6
YANGON	RGN	+6.5
BANGKOK	BKK	+7
SINGAPORE	SIN	+8
HONGKONG	HKG	+8
BEIJING	BJS	+8
TAIPEI	TPE	+8
SEOUL	SEL	+9

City	Code	Time Zone
TOKYO	TYO	+9
ADELAIDE	ADL	+9.5
GUAM	GUM	+10
SYDNEY	SYD	+10
NOUMEA	NOU	+11
WELLINGTON	WLG	+12
PAGO PAGO	PPG	-11
HONOLULU	HNL	-10
ANCHORAGE	ANC	-9
VANCOUVER	YVR	-8
LOS ANGELES	LAX	-8
EDMONTON	YEA	-7
DENVER	DEN	-7
MEXICO CITY	MEX	-6
CHICAGO	CHI	-6
NEW YORK	NYC	-5
SANTIAGO	SCL	-4
HALIFAX	YHZ	-4
SAINT JOHN'S	YYT	-3.5
RIO DE JANEIRO	RIO	-3
F.DENORONHA	FEN	-2
PRAIA	RAI	-1

NOTES:

- *If you do not see your city code in the above list, check for the city closest to where you are using your Z1, and use its city code.*
- *The time difference is based on Coordinated Universal Time [UTC].*

About Trademarks

- The name Bluetooth® and its logos are registered trademarks owned by Bluetooth SIG, Inc. Any use of these marks by SCUBAPRO is under license. Other trademarks and trade names are those of their respective owners.
- Android, Google Play and other marks are trademarks of Google Inc.
- App Store is a service mark of Apple Inc.

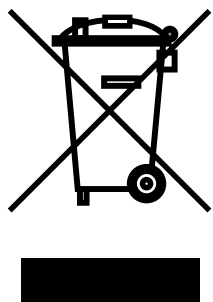

Your dive instrument is manufactured with high-quality components that can be recycled and reused. Nevertheless, these components, if not properly managed in accordance with the regulations on electrical and electronic equipment waste, are likely to cause harm to the environment and/or to human health. Customers living in the European Union can contribute to protecting the environment and health by returning old products to an appropriate collection point in their neighborhood in accordance with EU Directive 2012/19/UE. Collection points are provided by some distributors of the products and local authorities. Products marked with the recycling symbol on the left must not be disposed of in normal household waste.

